

314D LCR

Hydraulic Excavators



Engine

Engine Model	Cat® C4.2 ACERT™
Gross Power	72 kW/95.6 hp
Net Power (SAE J1349)	67 kW/88.7 hp

Weights

Operating Weight – Long Undercarriage	14 240 kg
---------------------------------------	-----------

314D LCR Features

Comfortable Operator Station

Quiet and spacious, this world class ROPS cab enables the operator to focus exclusively on performance and productivity.

Engine Power Combined with Low Emissions

Move more material while respecting the environment and consuming less fuel with the new Cat® C4.2 engine. The 314D LCR meets EU Stage IIIA emissions regulations, while delivering additional power and performance.

Maximum Versatility

Easily configure a large variety of work tools with the Cat® Tool Control System.

Proven Reliability

Caterpillar design and manufacturing techniques provide maximum uptime with outstanding durability and service life.

Compact Radius

The shorter tail swing and tighter front swing radius allow the operator to work more efficiently and in even safer conditions on space-restricted, congested or confined job sites, focusing more on the work at hand and less on counterweight clearance.

Complete Customer Support

Your Cat dealer offers a wide range of services that can be set up under a customer support agreement when you purchase your equipment. The dealer will help you choose a plan that can cover everything from machine configuration to eventual replacement.

Contents

Operator Station.....	3
Hydraulics	4
Front Linkage	5
Engine	6
Undercarriage and Structures	7
Versatility.....	8
Serviceability	9
314D LCR Hydraulic Excavator Specifications.....	10
314D LCR Standard Equipment	21
314D LCR Optional Equipment.....	21
Notes.....	22



Achieve high productivity and lower operating costs with the Cat® 314D LCR Hydraulic Excavator. Unmatched versatility thanks to its compact design, improved controllability, easy operation and a comfortable cab make the 314D LCR the industry leading performer.

Operator Station

Enhanced comfort, operation and visibility.

Operator Comfort

Experience a spacious, quiet and comfortable operator station. The cab is pressurized to 0.5 bar in order to reduce the amount of dust that enters the cab, keeping the operator comfortable during the entire shift, while assuring high productivity.

- The comfortable seat adjusts to the operator's size and weight, and the armrests are also height adjustable.
- The new seat has been designed to feature air suspension and heating systems, which are optionally available.
- Low effort joystick controls are designed to match the operator's natural wrist and arm position. Joysticks can be manipulated with arms on the armrests. The horizontal and vertical strokes are designed to reduce fatigue.
- The front windshield is split 70 (upper)/30 (lower) in order to provide maximum visibility. The upper part slides, assisted by a mechanism which reduces operator effort.

Cab Exterior (ROPS)

A Roll Over Protective Structure cab (ROPS) is standard on CE-compliant units and provides 10 percent more glass area than the previous non-ROPS cab. The optional Falling Objects Guard System (FOGS) can be directly bolted onto the cab in order to keep the operator safe. The machine, therefore, has the capability to meet all specifications and job site requirements. Thicker, steel tubes made according to the solid drawn process contribute to the rigidity of the 314D LCR's operator station. The cab shell is attached to the frame and viscous rubber cab mounts that dampen vibrations and sound level to enhance operator comfort.

Pre-start Check and Monitor Display

Take advantage of the entirely rethought monitor, designed to simplify machine use by acting as an operator to machine interface. It features:

- Full color graphical display
- An on-board servicing scheduler (displays recommended actions such as oil and filter changes)
- 20 different available languages
- Video display capability



Hydraulics

Low effort and precise control for highly efficient performance.



Outstanding Performance

With two percent more hydraulic pressure, the 314D LCR's hydraulic system is designed for high efficiency and performance.

- Hydraulic snubbers at the rod end of the boom cylinder and both ends of the stick cylinder cushion shock, reduce sound and increase cylinder life.
- Flow is reduced to a minimum when controls are in neutral to reduce fuel consumption and extend component life. Electronic underspeed control electronically adjusts pump output so it does not exceed engine power, eliminating the need to reserve engine power to avoid engine stalls.
- Hydraulic cross sensing system contributes to improving productivity with faster implement speeds and quicker, stronger pivot turns.
- Two-pump combined function incorporated into the main control valve enables you to reduce costs and downtime while modifying in the field.

On Demand Power Supply (ODPS)

During lighter load conditions lasting more than five seconds in the hydraulic circuit, ODPS automatically reduces engine speed to an rpm level equal to dial nine in order to adjust the power to the load. Fuel consumption reduces when the machine does not require high power. Engine rpm increase almost immediately when a heavier load is detected. In lighter load conditions, engine rpm decrease but the overall hydraulic cycle speed remains unchanged. Conversely, when ODPS delivers high power, the operator may notice an increase in engine speed.

Boom and Stick Regeneration Circuits

The 314D LCR uses boom and stick regeneration circuits to save energy (fuel) during boom-down and stick-in operations. Boom-down operation is electronically assisted.

Easy Operation

The 314D LCR has an automatic boom and swing priority function that selects the best mode based on the amount of lever movement. Work and power mode switches have been eliminated to simplify operation and optimize performance.

Medium Pressure Circuit

Available as an attachment for work tools requiring moderate hydraulic flow such as rotating buckets or shears.

High Pressure Circuits

Available as an attachment for work tools requiring high hydraulic flow or pressure such as hammers, processors and shears.



Front Linkage

Reliable, durable and versatile.

Built for performance and long service life, Cat booms and sticks are welded, box section structures with thick, multi-plate, high strength steel fabrications. Service intervals are extended with self-lubricating pins that resist corrosion and galling for superior durability.

Reach Boom

The 4.3 m reach boom is designed for maximum digging capability and is robotic welded to ensure consistent quality. This allows excellent all around versatility and a large working envelope.

Optional Variable Angle Boom

A new, optional VA boom is available to suit all your applications in small space conditions and achieve greater versatility.

Sticks

Two lengths of sticks are available (2.5 m and 3.0 m) in order to offer maximum flexibility in machine configuration and, therefore, meet a wide range of applications. What is more, all the boom and stick linkages of the 314D LCR are compatible with those of the 314C.

Engine

Delivering the most work per liter of fuel consumed.



The Cat® C4.2 engine with ACERT™ Technology optimizes performance and meets EU Stage IIIA emissions regulations. Integrated electronics coupled with ACERT Technology reduces emissions during combustion by using advanced technology in the air and fuel systems. Delivering exceptional power, the C4.2 allows more hydraulic pressure to drive productivity and reduce the cost per ton of material moved.

Fuel Economy

- **Automatic Engine Control, Fuel Delivery and Manual Low Idle Function**

Two level control with one-touch command maximizes fuel efficiency and reduces sound levels. ADEM™ A4 engine controller manages fuel delivery for the best performance per liter of fuel used. With flexible fuel mapping, the engine responds quickly to various applications. Multiple injection fuel delivery involves a high level of precision, and consequently, the carefully shaped combustion cycle lowers combustion chamber temperatures and generates fewer emissions optimizing fuel consumption.

- **Economy Mode**

Standard function enables you to adapt machine performance to the application. You can switch Economy Mode ON/OFF and decide if you want to operate fuel efficiently or use the machine's full power to achieve maximum productivity.

- **On Demand Power Supply (ODPS)**

New feature constantly regulates engine power supply based on the power demanded by the hydraulic system to reduce fuel consumption and machine noise in light duty applications.

Electronic Control Module

“Brain” of the engine's control system, responds quickly to the operating variable to maximize engine efficiency. The ECM stores and relays data on conditions such as rpm, fuel consumption and diagnoses.

Crankshaft and Pistons

Forged one-piece induction hardened crankshaft enhances balance, decreases vibration and improves abrasion resistance. Heat resistant, aluminum alloy pistons have a short compression height for greater efficiency and longer life.



Undercarriage and Structures

Strong, stable and easy to maneuver.

Caterpillar uses advanced engineering and software to analyze all structures, creating a durable, reliable machine for the toughest applications. More than 70 percent of the structural welds are robotic and achieve over three times the penetration of manual welds. These structural components and undercarriage are the backbone of the machine's durability.

Long Undercarriage

The 314D LCR has a long undercarriage for you to enjoy great stability in all conditions.

Blades

There are three blades available for the 314D LCR.

Carbody Design

X-shaped, box section carbody provides excellent resistance to torsional bending. Robot-welded track roller frames are press-formed, pentagonal units that deliver exceptional strength and service life. Idler and center guards are standard to help maintain track alignment when traveling or working on slopes.

Travel Motors

Travel motors with automatic speed selection let the 314D LCR automatically change up and down from high and low speeds in a smooth and controlled manner.

Grease Lubricated Tracks

Grease lubricated track seals protect the track link and track pin and bushing inner wear and increase life by as much as 25 percent, when compared to dry seal undercarriages.

Versatility

More options for more work.



Compact Radius Design

The 314D LCR is ideal for works in confined areas such as urban constructions. Its design brings an optimized working envelop and a swing radius within track width for easy and safe operations even in extremely restricted sites.

Hydraulic and Pilot Configurations

High pressure systems, medium pressure systems and hydraulic controls are available as independent and combinable attachments so you can configure a machine perfectly adapted to your specific job needs.

Controls

An optional, two position (ON/OFF) foot switch without modulation is available. Alternatively, there is an optional pedal that provides foot pedal modulation.

Work Tools

Caterpillar offers a variety of work tools including hammers, grapples, multiprocessors, shears, pulverizers and vibratory compactors to fit your application needs. A wide range of buckets is available to optimize machine performance. Auxiliary hydraulic and electrical lines are routed to the boom foot for easier installation of auxiliary hydraulic circuits, reducing the time and cost to add a work tool. All pins are interchangeable between the Cat C-Series and the D-Series models.

Tool Control System

Standard system stores up to 10 flow and pressure settings for easier and quicker tool readiness. Combined with the hydraulic quick coupler, the Tool Control System lets you change from one hydraulic work tool to another without leaving the cab.

Quick Couplers

The hydraulic quick coupler increases machine versatility by making the change from one hydraulic work tool to another quick and easy. A universal quick coupler control accepts all hydraulic quick coupler systems with pressure ranging up to the full machine pressure of 350 bar.

Cat® K Series™ Tooth System

Provides reliable tip retention and easy tip installation and removal.

High Ambient Cooling Package

The 314D LCR can work in temperatures up to 48° C with this EU compliant package.



Serviceability

Simplified service and maintenance save time and money.

Designed with the service technician in mind, many service locations are at ground level so that critical maintenance can be done quickly and efficiently. Longer maintenance intervals reduce cost and increase machine availability.

- Oil level gauge, fuel filter and priming pump are conveniently located on the right side of the engine structure for easy maintenance.
- Optional electronic fuel water sensor is available to alert operator when the water level is high.
- Product Link assists with fleet management by tracking hours, fleet location and product health.
- New anti-skid plates over the top of the storage box and upper structure help prevent slipping and mud from falling into the upper structure.
- ROPS cab air filter accessible at ground level.

Sampling Ports

Equipped with S•O•SSM sampling ports and test ports for hydraulics, engine oil and coolant for diagnoses. A test connection for the Cat Electronic Technician (Cat ET) service tool is located in the cab.

Air Cleaner

A double layered filter core in the radial seal air filter gives more efficient filtration. A warning is displayed on the monitor when dust accumulates above a preset level. This filter is conveniently placed in the compartment behind the cab.

Capsule Filter

A capsule type hydraulic return filter is accessible from outside the tank and prevents contaminants from entering the system during hydraulic oil changes.

Water Separator with Indicator

An optional water separator with level indicator to alert the operator when the water level is high.

314D LCR Hydraulic Excavator Specifications

Engine

Engine Model	Cat® C4.2 ACERT™
Gross Power	72 kW/95.6 hp
Net Power (SAE J1349)	67 kW/88.7 hp
SAE J1349	67 kW/88.7 hp
Bore	102 mm
Stroke	130 mm
Displacement	4.25 L

- All engine horsepower (hp) are metric, including cover.
- Net power advertised is the power available at the flywheel when the engine is equipped with fan, air cleaner, muffler and alternator.
- No engine power derating required below 2300 m.
- The 314D LCR meets EU Stage IIIA Directive 97/68/EC emissions requirements.

Weights

Operating Weight	14 240 kg
– Long Undercarriage	

- Weight includes 500 mm shoe, 0.43 m³ bucket, long stick (3.0 m) and standard counterweight.

Swing Mechanism

Swing Torque	30.9 kN·m
Swing Speed	11.5 rpm

Drive

Maximum Drawbar Pull	113 kN
Travel Speed	5.5 km/h

Hydraulic System

Main Implement System – Maximum Flow (2x)	127 L/min
Maximum Pressure – Implements	305 bar
Maximum Pressure – Travel	350 bar
Maximum Pressure – Swing	230 bar
Pilot System – Maximum Flow	21.1 L/min
Pilot System – Maximum Pressure	41 bar
Blade – Maximum Flow	47 L/min
Blade System – Maximum Pressure	206 bar
Boom Cylinder – Bore	110 mm
Boom Cylinder – Stroke	1000 mm
Stick Cylinder – Bore	120 mm
Stick Cylinder – Stroke	1197 mm
Bucket Cylinder – Bore	100 mm
Bucket Cylinder – Stroke	939 mm

Service Refill Capacities

Fuel Tank	186 L
Cooling System	18 L
Engine Oil	19 L
Swing Drive (each)	3 L
Final Drive (each)	3 L
Hydraulic System (including Tank)	160 L
Hydraulic Tank	120 L

Standards

Cab/FOGS	SAE J1356 FEB88 ISO 10262
Cab/ROPS	Cat cab with integrated Roll Over Protective Structure (ROPS) meets ISO 12117-2:2008 criteria.

Sound

Operator Sound

- The operator sound level measured according to the procedures specified in ISO 6396 is 74 dB(A) for cab offered by Caterpillar, when properly installed and maintained and tested with the doors and windows closed.
- Hearing protection may be needed when operating with an open operator station and cab (when not properly maintained or doors/windows open) for extended periods or in noisy environment.

Exterior Sound

- The labeled spectator sound power level measured according to the test procedures and conditions specified in 2000/14/EC is 100 dB(A).

Dimensions

All dimensions are approximate.

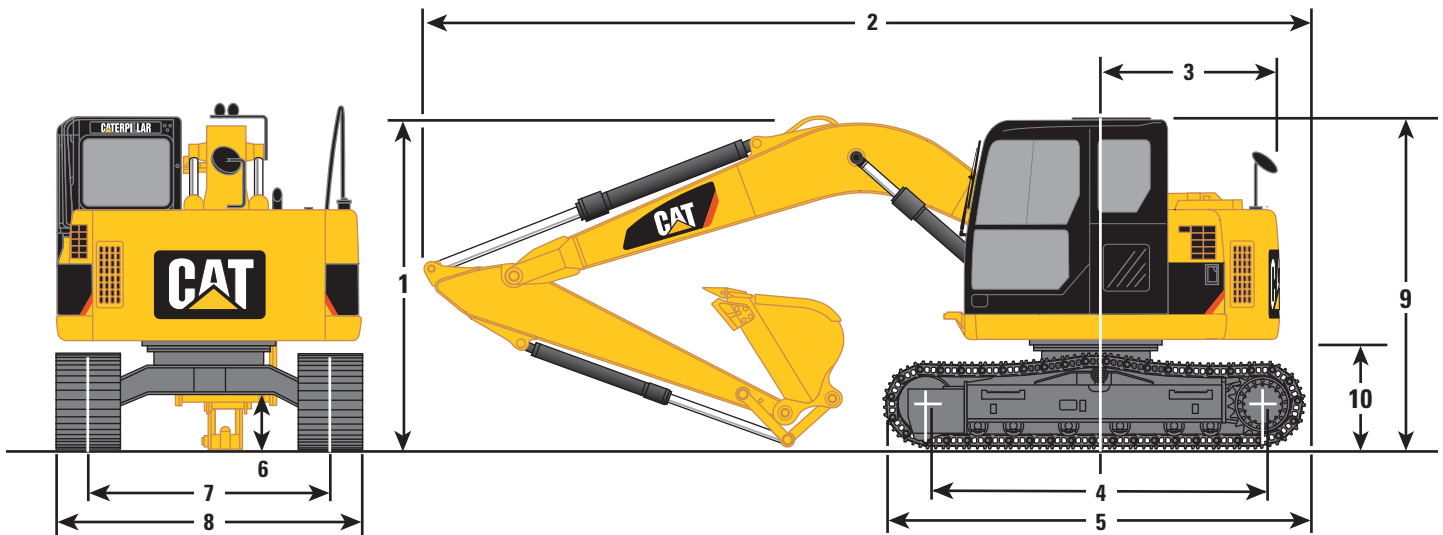

Boom Options	Reach	Reach	Reach
Stick Options	2.5 m	2.8 m	3.0 m
1 Shipping Height	2910 mm	3030 mm	2910 mm
2 Shipping Length	7270 mm	7390 mm	7410 mm
3 Tail Swing Radius (with standard counterweight)	1480 mm	1480 mm	1480 mm
4 Length to Center of Rollers			
314D LCR	3040 mm	3040 mm	3040 mm
5 Track Length			
314D LCR	3750 mm	3750 mm	3750 mm
6 Ground Clearance	430 mm	430 mm	430 mm
7 Track Gauge			
314D LCR	1990 mm	1990 mm	1990 mm
8 Transport Width	500 mm Shoes	600 mm Shoes	700 mm Shoes
314D LCR	2490 mm	2590 mm	2690 mm
9 Cab Height	2730 mm	2730 mm	2730 mm
10 Counterweight Clearance	895 mm	895 mm	895 mm

Operating Weights (with standard counterweight)

Caterpillar designed and built track-type undercarriage.

Track Width	Operating Weight		
	2.5 m Stick	2.8 m Stick	3.0 m Stick
314D LCR 500 mm triple grouser	14 240 kg	14 240 kg	14 240 kg
600 mm triple grouser	14 440 kg	14 540 kg	14 540 kg
700 mm triple grouser	14 740 kg	14 740 kg	14 740 kg
500 mm triple grouser with blade	15 040 kg	15 040 kg	15 040 kg
600 mm triple grouser with blade	15 340 kg	15 340 kg	15 340 kg
700 mm triple grouser with blade	15 540 kg	15 540 kg	15 540 kg
	0.52 m ³ bucket	0.40 m ³ bucket	0.40 m ³ bucket

314D LCR Hydraulic Excavator Specifications

Working Ranges

All dimensions are approximate.

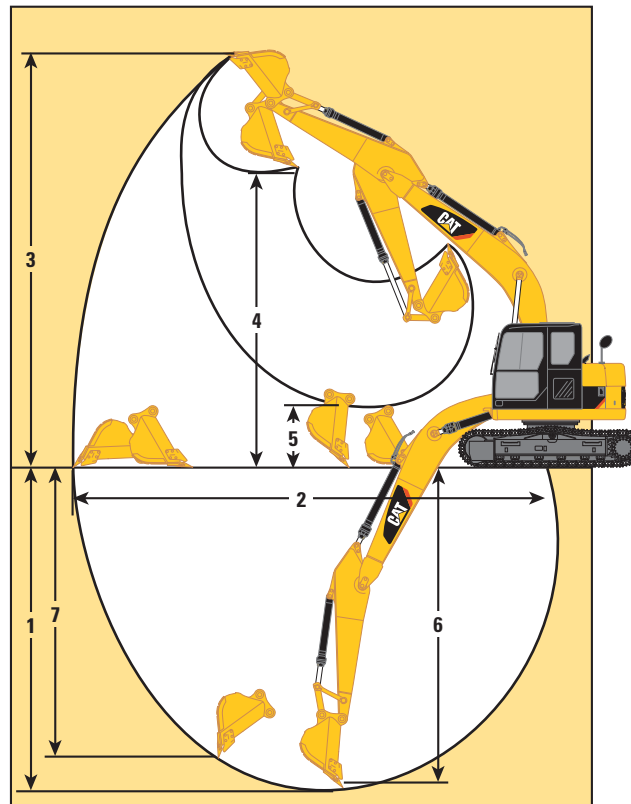

Boom	Reach 4.65 m	Reach 4.65 m	Reach 4.65 m
Stick	2.5 m*	2.8 m*	3.0 m*
Bucket	0.52 m ³	0.40 m ³	0.40 m ³
1 Maximum Digging Depth	5440 mm	5740 mm	5940 mm
2 Maximum Reach at Ground Level	8180 mm	8440 mm	8630 mm
3 Maximum Cutting Height	9300 mm	9470 mm	9630 mm
4 Maximum Loading Height	6870 mm	7040 mm	7200 mm
5 Minimum Loading Height	2510 mm	2250 mm	2060 mm
6 Maximum Depth Cut for 2440 m Level Bottom	5240 mm	5550 mm	5760 mm
7 Maximum Vertical Wall Digging Depth	4910 mm	5080 mm	5280 mm
Minimum Front Swing Radius	1980 mm	2160 mm	2230 mm
Stick Digging Force (SAE)	64 kN	60 kN	57 kN
Bucket Digging Force (SAE)	85 kN	85 kN	85 kN

* Measurements shown are for machines equipped with the 0.52 m³ buckets.

Buckets

Buckets have tapered sides, angled corner teeth, dual radius curvature, horizontal wear strips and holes for optional side cutters.

Width mm	Capacity m ³	Recommended Maximum Material Density		
		2.5 m Stick kg/m ³	2.8 m Stick kg/m ³	3.0 m Stick kg/m ³
598	0.30	1800	1800	1800
748	0.40	1800	1800	1800
903	0.52	1800	1800	1500
1055	0.63	1500	1200	1200
1206	0.74	1200	1200	900

Material Densities

Material	kg/m ³ *	Material	kg/m ³ *
Clay, dry	1480	Gravel, pit run	1930
Clay, wet	1660	Rock/dirt, 50%	1720
Earth, dry	1510	Sand, dry	1420
Earth, wet	1600	Sand, wet	1840
Loam	1250	Sand and Clay	1600
Gravel, dry	1510	Stone, crushed	1600
Gravel, wet	2020	Top soil	950

* kilograms per loose cubic meter

For densities of other materials see Caterpillar Performance Handbook.

Undercarriage

Caterpillar designed and built track-type undercarriage.

Track Width	Ground Pressure
500 mm triple grouser	0.42 bar
600 mm triple grouser	0.36 bar
700 mm triple grouser	0.31 bar

With standard counterweight, 0.4 m³ bucket.

Track Width	Ground Pressure
500 mm triple grouser	0.44 bar
600 mm triple grouser	0.37 bar
700 mm triple grouser	0.32 bar

With optional counterweight, 0.4 m³ bucket.

314D LCR Hydraulic Excavator Specifications

314D LCR Reach Boom Lift Capacities

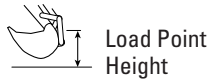

Load Point Height



Load at Maximum Reach



Load Radius Over Front

















Load Radius Over Side

STICK – 3.0 m
BUCKET – 0.40 m³

UNDERCARRIAGE – Long
SHOES – 600 mm triple grouser















BOOM – 4.65 m
BLADE – None

		1.5 m		3.0 m		4.5 m		6.0 m		7.5 m				m
														
7.5 m	kg					*1500	*1500					*1300	*1300	5.24
6.0 m	kg					*2400	*2400	*2050	*2050			*1500	*1500	6.51
4.5 m	kg					*3100	*3100	*2900	2200			*1450	*1450	7.30
3.0 m	kg			*4700	*4700	*3900	3400	*3200	2100	*2300	1400	*1450	1300	7.77
1.5 m	kg					*4800	3100	3300	1950	2300	1350	*1550	1200	7.95
0 m	kg			*5300	*5300	5050	2850	3200	1850	2250	1300	*1700	1200	7.80
-1.5 m	kg	*3850	*3850	*7150	5300	4950	2800	3100	1800			*2000	1300	7.32
-3.0 m	kg	*5850	*5850	*5600	5400	*4100	2800	*2800	1800			*2350	1650	6.42
-4.5 m	kg					*1950	*1950					*1600	*1600	4.86

STICK – 2.8 m
BUCKET – 0.40 m³

UNDERCARRIAGE – Long
SHOES – 600 mm triple grouser















BOOM – 4.65 m
BLADE – None

		1.5 m		3.0 m		4.5 m		6.0 m		7.5 m				m
														
7.5 m	kg					*1450	*1450					*1300	*1300	4.94
6.0 m	kg					*2450	*2450	*2050	*2050			*1650	*1650	6.28
4.5 m	kg					*3300	*3300	*3000	2200			*1600	1550	7.10
3.0 m	kg			*5850	*5850	*4050	3350	*3300	2100			*1600	1350	7.58
1.5 m	kg					*4950	3100	3300	1950	2300	1350	*1700	1250	7.76
0 m	kg			*5000	*5000	5050	2850	3200	1850			*1850	1250	7.61
-1.5 m	kg	*3900	*3900	*6350	5350	4950	2800	3150	1800			*2200	1400	7.12
-3.0 m	kg			*5250	*5250	*3950	2800	*2600	1850			*2400	1750	6.18
-4.5 m	kg													

STICK – 2.5 m
BUCKET – 0.52 m³

UNDERCARRIAGE – Long
SHOES – 600 mm triple grouser

BOOM – 4.65 m
BLADE – None

		1.5 m		3.0 m		4.5 m		6.0 m		7.5 m				m
														
7.5 m	kg											*1200	*1200	4.53
6.0 m	kg					*2400	*2400					*1700	*1700	5.97
4.5 m	kg					*3500	*3500	*3150	2150			*1600	*1600	6.82
3.0 m	kg			*6450	6350	*4250	3300	*3400	2050			*1650	1400	7.32
1.5 m	kg					*5050	3050	3300	1950			*1700	1300	7.51
0 m	kg					5000	2850	3200	1850			*1900	1300	7.35
-1.5 m	kg	*3800	*3800	*5500	5400	*4850	2800	3150	1800			*2250	1500	6.84
-3.0 m	kg			*4650	*4650	*3600	2850					*2300	1950	5.85
-4.5 m	kg													

*Indicates that the load is limited by hydraulic lifting capacity rather than tipping load. The above loads are in compliance with hydraulic excavator lift capacity standard ISO 10567:2007. They do not exceed 87% of hydraulic lifting capacity or 75% of tipping load. Weight of all lifting accessories must be deducted from the above lifting capacities. Lifting capacities are based on the machine standing on a firm, uniform supporting surface.

Always refer to the appropriate Operation and Maintenance Manual for specific product information.

314D LCR Reach Boom Lift Capacities

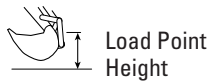

Load Point
Height



Load at
Maximum Reach



Load Radius
Over Front

















Load Radius
Over Side

STICK – 3.0 m
BUCKET – 0.40 m³

UNDERCARRIAGE – Long
SHOES – 600 mm triple grouser















BOOM – 4.65 m
BLADE – Blade up

		1.5 m		3.0 m		4.5 m		6.0 m		7.5 m				m
														
7.5 m	kg					*1500	*1500					*1300	*1300	5.24
6.0 m	kg					*2400	*2400	*2050	*2050			*1500	*1500	6.51
4.5 m	kg					*3100	*3100	*2900	2350			*1450	*1450	7.30
3.0 m	kg			*4700	*4700	*3900	3600	*3200	2250	*2300	1500	*1450	1400	7.77
1.5 m	kg					*4800	3300	3300	2100	2300	1450	*1550	1300	7.95
0 m	kg			*5300	*5300	5050	3050	3200	2000	2250	1400	*1700	1300	7.80
-1.5 m	kg	*3850	*3850	*7150	5650	4950	2950	3100	1900			*2000	1400	7.32
-3.0 m	kg	*5850	*5850	*5600	*5600	*4100	3000	*2800	1950			*2350	1750	6.42
-4.5 m	kg					*1950	*1950					*1600	*1600	4.86

STICK – 3.0 m
BUCKET – 0.40 m³

UNDERCARRIAGE – Long
SHOES – 600 mm triple grouser















BOOM – 4.65 m
BLADE – Blade down

		1.5 m		3.0 m		4.5 m		6.0 m		7.5 m				m
														
7.5 m	kg					*1500	*1500					*1300	*1300	5.24
6.0 m	kg					*2400	*2400	*2050	*2050			*1500	*1500	6.51
4.5 m	kg					*3100	*3100	*2900	2600			*1450	*1450	7.30
3.0 m	kg			*4700	*4700	*3900	*3900	*3200	2500	*2300	1700	*1450	*1450	7.77
1.5 m	kg					*4800	3700	*3550	2350	*2900	1650	*1550	1450	7.95
0 m	kg			*5300	*5300	*5250	3500	*3800	2250	*2850	1600	*1700	1500	7.80
-1.5 m	kg	*3850	*3850	*7150	6550	*5050	3400	*3600	2200			*2000	1600	7.32
-3.0 m	kg	*5850	*5850	*5600	*5600	*4100	3400	*2800	2200			*2350	2000	6.42
-4.5 m	kg					*1950	*1950					*1600	*1600	4.86

STICK – 2.8 m
BUCKET – 0.40 m³

UNDERCARRIAGE – Long
SHOES – 600 mm triple grouser

BOOM – 4.65 m
BLADE – Blade up

		1.5 m		3.0 m		4.5 m		6.0 m		7.5 m				m
														
7.5 m	kg					*1450	*1450					*1300	*1300	4.94
6.0 m	kg					*2450	*2450	*2050	*2050			*1650	*1650	6.28
4.5 m	kg					*3300	*3300	*3000	2300			*1600	*1600	7.10
3.0 m	kg			*5850	*5850	*4050	3550	*3300	2200			*1600	1450	7.58
1.5 m	kg					*4950	3250	3300	2100	2300	1450	*1700	1350	7.76
0 m	kg			*5000	*5000	5050	3050	3200	2000			*1850	1350	7.61
-1.5 m	kg	*3900	*3900	*6350	5700	4950	3000	3150	1950			*2200	1500	7.12
-3.0 m	kg			*5250	*5250	*3950	3000	*2600	1950			*2400	1900	6.18
-4.5 m	kg													

*Indicates that the load is limited by hydraulic lifting capacity rather than tipping load. The above loads are in compliance with hydraulic excavator lift capacity standard ISO 10567:2007. They do not exceed 87% of hydraulic lifting capacity or 75% of tipping load. Weight of all lifting accessories must be deducted from the above lifting capacities. Lifting capacities are based on the machine standing on a firm, uniform supporting surface.

Always refer to the appropriate Operation and Maintenance Manual for specific product information.

314D LCR Hydraulic Excavator Specifications

314D LCR Reach Boom Lift Capacities

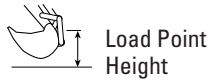

Load Point Height



Load at Maximum Reach



Load Radius Over Front

















Load Radius Over Side

STICK – 2.8 m
BUCKET – 0.40 m³

UNDERCARRIAGE – Long
SHOES – 600 mm triple grouser















BOOM – 4.65 m
BLADE – Blade down

		1.5 m		3.0 m		4.5 m		6.0 m		7.5 m				m
														
7.5 m	kg					*1450	*1450					*1300	*1300	4.94
6.0 m	kg					*2450	*2450	*2050	*2050			*1650	*1650	6.28
4.5 m	kg					*3300	*3300	*3000	2600			*1600	*1600	7.10
3.0 m	kg			*5850	*5850	*4050	4000	*3300	2500			*1600	*1600	7.58
1.5 m	kg					*4950	3700	*3650	2350	*2750	1650	*1700	1550	7.76
0 m	kg			*5000	*5000	*5300	3500	*3800	2250			*1850	1550	7.61
-1.5 m	kg	*3900	*3900	*6350	*6350	*4950	3400	*3550	2200			*2200	1700	7.12
-3.0 m	kg			*5250	*5250	*3950	3450	*2600	2250			*2400	2150	6.18
-4.5 m	kg													

STICK – 2.5 m
BUCKET – 0.52 m³

UNDERCARRIAGE – Long
SHOES – 600 mm triple grouser















BOOM – 4.65 m
BLADE – Blade up

		1.5 m		3.0 m		4.5 m		6.0 m		7.5 m				m
														
7.5 m	kg											*1200	*1200	4.53
6.0 m	kg					*2400	*2400					*1700	*1700	5.97
4.5 m	kg					*3500	*3500	*3150	2250			*1600	*1600	6.82
3.0 m	kg			*6450	*6450	*4250	3500	*3400	2200			*1650	1500	7.32
1.5 m	kg					*5050	3200	3300	2050			*1700	1400	7.51
0 m	kg					5000	3050	3200	1950			*1900	1450	7.35
-1.5 m	kg	*3800	*3800	*5500	*5500	*4850	3000	3150	1950			*2250	1600	6.84
-3.0 m	kg			*4650	*4650	*3600	3050					*2300	2050	5.85
-4.5 m	kg													

STICK – 2.5 m
BUCKET – 0.52 m³

UNDERCARRIAGE – Long
SHOES – 600 mm triple grouser

BOOM – 4.65 m
BLADE – Blade down

		1.5 m		3.0 m		4.5 m		6.0 m		7.5 m				m
														
7.5 m	kg											*1200	*1200	4.53
6.0 m	kg					*2400	*2400					*1700	*1700	5.97
4.5 m	kg					*3500	*3500	*3150	2550			*1600	*1600	6.82
3.0 m	kg			*6450	*6450	*4250	3950	*3400	2450			*1650	*1650	7.32
1.5 m	kg					*5050	3650	*3700	2350			*1700	1600	7.51
0 m	kg					*5300	3450	*3800	2250			*1900	1650	7.35
-1.5 m	kg	*3800	*3800	*5500	*5500	*4850	3400	*3450	2200			*2250	1800	6.84
-3.0 m	kg			*4650	*4650	*3600	3450					*2300	*2300	5.85
-4.5 m	kg													

*Indicates that the load is limited by hydraulic lifting capacity rather than tipping load. The above loads are in compliance with hydraulic excavator lift capacity standard ISO 10567:2007. They do not exceed 87% of hydraulic lifting capacity or 75% of tipping load. Weight of all lifting accessories must be deducted from the above lifting capacities. Lifting capacities are based on the machine standing on a firm, uniform supporting surface.

Always refer to the appropriate Operation and Maintenance Manual for specific product information.

Working Ranges

All dimensions are approximate.

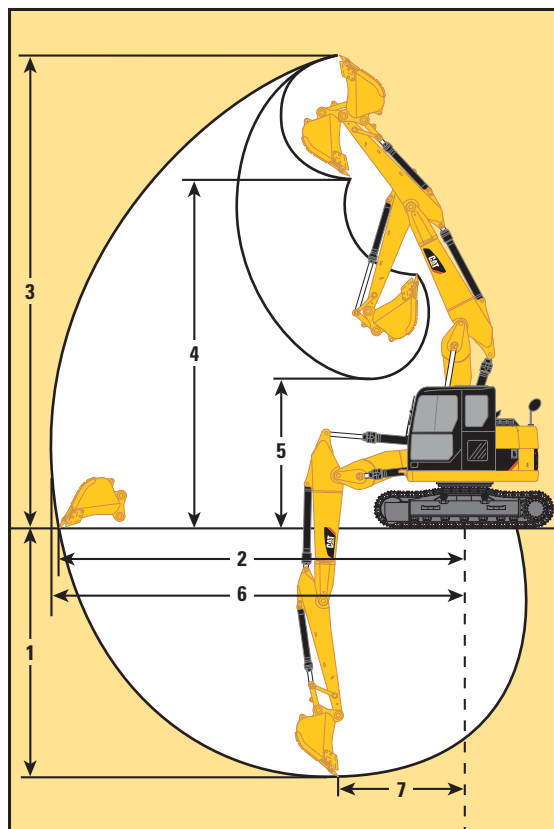

Boom	Variable Angle
Stick	R2.3.312 (2250 mm)*
Bucket	0.40 m ³
1 Maximum Digging Depth	4840 mm
2 Maximum Radius at Ground Line	8030 mm
3 Maximum Bucket Teeth Height	9150 mm
4 Minimum Clearance of Bucket Teeth, with Bucket Pivot at Maximum Height	6750 mm
5 Minimum Clearance of Bucket Teeth at Maximum Boom Height	2890 mm
6 Maximum Radius of Working Equipment	8170 mm
7 Radius of Maximum Digging Depth	2490 mm
Radius of Bucket Teeth at Maximum Height	2530 mm
Minimum Working Equipment Radius with Boom at Maximum Height and Stick Fully Retracted	2210 mm
Boom Cylinder Pivot to Axis of Rotation	599 mm
Boom Pivot to Axis of Rotation	145 mm
Boom Pivot to Ground Line	1516.2 mm
Boom Cylinder Pivot to Ground Line	1181.2 mm

* Measurements shown are for machines equipped with the 0.4 m³ buckets.

314D LCR Hydraulic Excavator Specifications

314D LCR VA Boom Lift Capacities

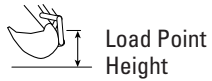

Load Point Height



Load at Maximum Reach



Load Radius Over Front















Load Radius Over Side

STICK – VAB 2.25 m
BUCKET – 0.40 m³

UNDERCARRIAGE – Long
SHOES – 600 mm triple grouser













BOOM – Variable Angle
BLADE – Blade up

		1.5 m		3.0 m		4.5 m		6.0 m				m
												
7.5 m	kg									*1150	*1150	3.88
6.0 m	kg					*2650	*2650			*1800	*1800	5.51
4.5 m	kg			*4150	*4150	*3800	3600	*3350	2200	*1950	1900	6.48
3.0 m	kg					*4500	3350	3300	2100	*1950	1600	7.02
1.5 m	kg					5050	3100	3200	2000	*2050	1450	7.17
0 m	kg					4850	2950	3100	1900	*2300	1500	6.98
-1.5 m	kg			*5750	5650	*4550	2900	3050	1900	*2750	1700	6.42
-3.0 m	kg			*3750	*3750	*3050	3000			*2200	*2200	5.34

STICK – VAB 2.25 m
BUCKET – 0.40 m³

UNDERCARRIAGE – Long
SHOES – 600 mm triple grouser

BOOM – Variable Angle
BLADE – Blade down

		1.5 m		3.0 m		4.5 m		6.0 m				m
												
7.5 m	kg									*1150	*1150	3.88
6.0 m	kg					*2650	*2650			*1800	*1800	5.51
4.5 m	kg			*4150	*4150	*3800	3650	*3350	2250	*1950	1900	6.48
3.0 m	kg					*4500	3400	3350	2150	*1950	1600	7.02
1.5 m	kg					5150	3150	3250	2050	*2050	1500	7.17
0 m	kg					4950	3000	3150	1950	*2300	1550	6.98
-1.5 m	kg			*5750	*5750	*4550	3000	3150	1950	*2750	1750	6.42
-3.0 m	kg			*3750	*3750	*3050	3050			*2200	*2200	5.34

*Indicates that the load is limited by hydraulic lifting capacity rather than tipping load. The above loads are in compliance with hydraulic excavator lift capacity standard ISO 10567:2007. They do not exceed 87% of hydraulic lifting capacity or 75% of tipping load. Weight of all lifting accessories must be deducted from the above lifting capacities. Lifting capacities are based on the machine standing on a firm, uniform supporting surface.

Always refer to the appropriate Operation and Maintenance Manual for specific product information.

Working Ranges

All dimensions are approximate.

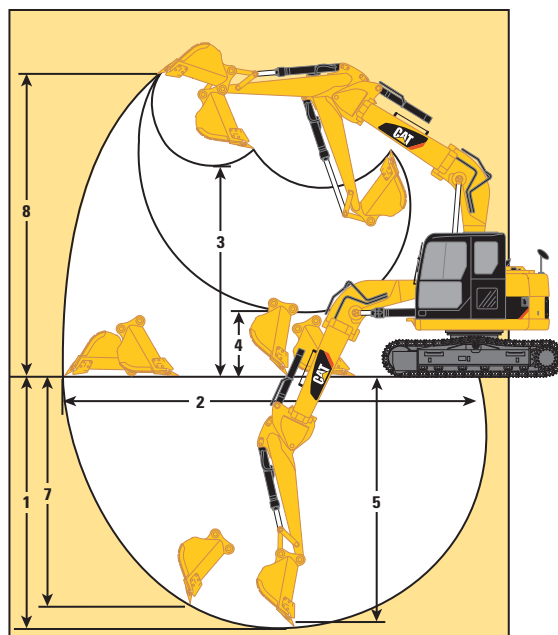

Boom	Power Offset
	4.37 m
Stick	2.1 m*
Bucket	0.40 m³
1 Maximum Digging Depth	4840 mm
2 Maximum Reach at Ground Level	7230 mm
3 Maximum Loading Height	5340 mm
4 Minimum Loading Height	2330 mm
5 Maximum Depth Cut for 2440 m Level Bottom	4470 mm
6 Minimum Front Swing Radius	2060 mm
7 Maximum Vertical Wall Digging Depth	3560 mm
8 Maximum Cutting Height	7640 mm
9 Left Hand Offset (from boom center)	1100 mm
10 Right Hand Offset (from boom center)	1150 mm
Stick Digging Force (SAE)	61 kN
Bucket Digging Force (SAE)	78 kN

* Measurements shown are for machines equipped with the 0.40 m³ buckets.

314D LCR Hydraulic Excavator Specifications

314D LCR Power Offset Boom Lift Capacities



Load Point Height



Load at Maximum Reach



Load Radius Over Front















Load Radius Over Side

STICK – POB 2.1 m
BUCKET – 0.40 m³

UNDERCARRIAGE – Long
SHOES – 600 mm triple grouser













BOOM – Offset-Boom (Center)
BLADE – Blade up

		1.5 m		3.0 m		4.5 m		6.0 m				m
												
6.0 m	kg					*2000	*2000			*1900	*1900	4.64
4.5 m	kg					*3600	*3600			*1900	*1900	5.85
3.0 m	kg			*6300	*6300	*4200	3450	*3350	2100	*2000	1850	6.44
1.5 m	kg					*4800	3100	3200	1950	*2250	1650	6.61
0 m	kg			*5100	*5100	4850	2850	3050	1850	*2700	1650	6.41
-1.5 m	kg			*5650	5350	*4250	2800			*3050	1900	5.78
-3.0 m	kg			*3450	*3450					*2550	*2550	4.56

STICK – POB 2.1 m
BUCKET – 0.40 m³

UNDERCARRIAGE – Long
SHOES – 600 mm triple grouser

BOOM – Offset-Boom (Center)
BLADE – Blade down

		1.5 m		3.0 m		4.5 m		6.0 m				m
												
6.0 m	kg					*2000	*2000			*1900	*1900	4.64
4.5 m	kg					*3600	*3600			*1900	*1900	5.85
3.0 m	kg			*6300	*6300	*4200	3900	*3350	2400	*2000	*2000	6.44
1.5 m	kg					*4800	3500	*3500	2250	*2250	1900	6.61
0 m	kg			*5100	*5100	*4850	3250	*3450	2100	*2700	1900	6.41
-1.5 m	kg			*5650	*5650	*4250	3200			*3050	2200	5.78
-3.0 m	kg			*3450	*3450					*2550	*2550	4.56

*Indicates that the load is limited by hydraulic lifting capacity rather than tipping load. The above loads are in compliance with hydraulic excavator lift capacity standard ISO 10567:2007. They do not exceed 87% of hydraulic lifting capacity or 75% of tipping load. Weight of all lifting accessories must be deducted from the above lifting capacities. Lifting capacities are based on the machine standing on a firm, uniform supporting surface.

Always refer to the appropriate Operation and Maintenance Manual for specific product information.

314D LCR Standard Equipment

Standard equipment may vary. Consult your Cat dealer for details.

Alternator, 50 amp	• Clock	Light, storage box mounted
Automatic engine speed control	• Filter/fluid change information	Mirrors (frame and cab)
Bolt-on Falling Object Guard System (FOGS) capability	• Level check for hydraulic oil, engine oil and coolant	Power train
Cab	• Warning messages	• Cat® C4.2 engine with ACERT™ Technology
Cab, ROPS	Light, interior	• 24-volt electric starter
• AM/FM radio, 24-volt	Literature holder	• Air intake heater
• Ashtray	Openable front windshield	• Water separator
• Coat hook	Openable skylight with sun shade	Radial seal air filter
• Beverage holder	Storage compartment	Undercarriage
• Economy mode	Travel control pedals with removable hand levers	• Idler section track guiding guards
• Horn	Door locks and cap locks with one-key security system	• Center section track guiding guards
• Language display monitor (full graphic/full color display)		• Track-type undercarriage with grease lubricated seals

314D LCR Optional Equipment

Optional equipment may vary. Consult your Cat dealer for details.

Auxiliary hydraulics	Counterweight	Secondary exit, rear window
Auxiliary hydraulic lines from boom and sticks	Fine swing control	Stick and boom configuration
Bucket linkage	Front windshield guard	• 3.0 m stick
Cab mounted working lights	Heavy-duty bottom guard	• 2.5 m stick
Cab mounted working lights with time delay function	High ambient cooling system	• 4.3 m reach boom
Cold weather start	Power supply 5A-12V	• VA boom
	Rain protector	• Power Offset Boom
	Right side boom lights	

314D LCR Hydraulic Excavator

For more complete information on Cat products, dealer services, and industry solutions, visit us on the web at www.cat.com

© 2010 Caterpillar Inc.
All rights reserved

Materials and specifications are subject to change without notice. Featured machines in photos may include additional equipment. See your Cat dealer for available options.

CAT, CATERPILLAR, SAFETY.CAT.COM, their respective logos, "Caterpillar Yellow" and the "Power Edge" trade dress, as well as corporate and product identity used herein, are trademarks of Caterpillar and may not be used without permission.

HEHH4000-01 (06-2010)
Replaces HEHH4000

