

# D3K/D4K/D5K

Track-Type Tractors

**CATERPILLAR**<sup>®</sup>



Cat <sup>®</sup> Cat C4.4 ACERT Diesel Engine	D3K	D4K	D5K
Net power (SAE J1349)	55.2 kW/75 hp	62.6 kW/85 hp	71.6kW/97 hp
<b>Weights</b>			
Operating weight – XL	7795 kg	8147 kg	9408 kg
Operating weight – LGP	8093 kg	8501 kg	9683 kg

## D3K, D4K and D5K Features

### Comfortable Cab

*Spacious cab and air suspension seat keep you comfortable all day.*

### Seat-Mounted Controls

*Intuitive seat-mounted controls improve operator performance and reduce fatigue.*

### SystemOne™ Undercarriage

*See a dramatic reduction in tractor owning and operating costs with the state-of-the-art SystemOne undercarriage.*

### AccuGrade™ Systems

*Revolutionary grade control systems improve accuracy and increase productivity – with less effort.*



### Contents

Operator Station .....	3
Hydrostatic Transmission Control .....	4
Engine .....	4
Undercarriage .....	5
AccuGrade Systems .....	6
Blade and Attachments .....	7
Hydrostatic Winch .....	8
Serviceability .....	9
Customer Support .....	9
Specifications .....	10
Standard and Optional Equipment .....	14

**The Cat® D3K, D4K and D5K Track-Type Tractors deliver superior performance and comfort while reducing your operating costs. The large spacious cab provides a comfortable work area. Intuitive seat-mounted controls are easy to use for greater job accuracy and efficiency. The innovative SystemOne undercarriage reduces maintenance time and costs – significantly impacting your bottom line. The AccuGrade Laser and GPS Systems help you get to grade faster, with fewer passes and less manpower. From the first cut to finish grade, the K series Track Type Tractor sets the standard.**

# Operator Station

Superior comfort keeps you productive, all day long.

The operator station is designed to keep operators comfortable, relaxed and productive throughout the long work shift. The D3K, D4K and D5K features

- Standard air conditioning with cab option.
- Spacious cab with generous leg room.
- Fully adjustable air suspension seat with a heated seat option for cold climates.
- Wide door openings for getting in and out of the cab easily.
- Clear view to the blade corners and bottom cutting edge, especially important in fine grading, working against foundations and curbing.
- Operator sound level has been lowered inside the cab 4 dB(A) to an industry leading 80 dB(A) –ANSI/SAE J1166 OCT 98. This provides a quiet, comfortable working environment reducing operator fatigue and increasing their productivity.

## Seat-Mounted Joystick Controls

For optimum comfort and precise control, the D3K, D4K and D5K feature ergonomically designed seat-mounted controls. Seat-mounted controls isolate vibrations from the operator, and provide independent seat and controls adjustment. Individual wrist pads and armrests can be adjusted independently for optimum comfort.

## Monitoring Package

Easy to read display provides vital system information. Buttons below the display allow the operator to select parameters for forward/reverse speed, blade response, steering response and decel pedal operation modes.

## Dozer Blade Control

Ergonomic joystick is easy to use and reduces operator fatigue. The intuitive control makes operating the tractor easy for both new and experienced operators. The new handle shape conforms to your hand for precise blade raise and tilt control with less operator fatigue. A thumb roller controls the blade angle and requires less effort than other competitive machines. A blade shake button on top of the handle provides momentary quick tilt movement to easily remove material from the blade.

## Combined Decel/Brake Pedal

Decel pedal serves combined function as engine speed control and brake. Depressing pedal through bottom of travel detent applies brake. Pedal mode can also be changed to control transmission speed with selection buttons on the display panel.



# Hydrostatic Transmission Control

Seat-mounted controls improve productivity.



## Speed and Direction Control

Speed, direction and steering are all controlled with a single, easy to use joystick for less effort and lower fatigue so you can get more done. The joystick controls direction and has three simple detented positions for travel – forward, reverse and neutral. With the machine in motion, simply move the joystick in the direction you wish to move the machine. The more the joystick is moved to the right or left, the tighter the turn. Regardless of ground conditions, steering is consistent and predictable.

## Infinitely Variable Speed Control

The speed control thumb wheel mounted on the joystick is used to infinitely increase and decrease speed, letting the operator select the optimum speed for ground and job conditions. It also eliminates power interruption when changing speeds. A speed recall button on the joystick is used to select pre-determined speed settings.

## Maneuverability

The power turn feature lets you handle large loads around corners or through hard spots. Power turn capability improves mobility in soft underfoot conditions and is very effective on side slopes. Counter-rotation provides easy, quick maneuvering in tight areas or congested job sites.



## Engine

ACERT™ technology reduces emissions, increases performance.

The Cat® C4.4 is a 4.4 L displacement, four cylinder, inline configured engine equipped with a Caterpillar common rail fuel system. It uses ACERT™ Technology, a series of Caterpillar engineered innovations that provide advanced electronic control, precision fuel delivery and refined air management, resulting in outstanding performance and lower emissions. It meets the EU Stage IIIA and Japan MOC Step 3 emissions standards.

The C4.4 delivers increased horsepower, outstanding durability, reliability and improved response to change in loads, delivering power when you need it. The engine is more compact, allowing the cab to sit more forward – this improves machine balance and provides greater operator comfort. The engine and transmission control systems are integrated to optimize performance and fuel efficiency.

# Undercarriage

Lower owning and operating costs.

Undercarriage is a significant portion of a tractor's owning and operating costs. Caterpillar offers two different undercarriage choices for lowest owning and operating costs for your application needs. A sealed and lubricated track (SALT) undercarriage is standard; SystemOne™ undercarriage is available as an option. Full length guarding on top of the track roller frame prevents abrasive material from falling down on moving parts.

Machine balance is the key to good grading performance. Greater track length and a stable platform lead to optimum balance, allowing you to complete jobs easier and quicker with the D4K than with competitive machines.

## SystemOne Undercarriage

With the revolutionary SystemOne undercarriage option, undercarriage maintenance time and costs are greatly reduced, lowering your costs and helping your bottom line. This innovative system uses a rotating bushing design which increases bushing life and eliminates the need for bushing turns. The rotating bushing combined with long wear life sprockets and center tread idler, increases the life and dependability of the entire system. Ideal for virtually any application or underfoot condition, the SystemOne undercarriage also features significantly less vibration for a better, more comfortable ride.

## Sealed and Lubricated Track (SALT) Undercarriage

The standard sealed and lubricated track (SALT) undercarriage is built for long life in rugged conditions. Segmented sprockets are easy to replace and less expensive than replacing the complete sprocket hub.

## Choice of Track Frame Configurations

Track frames are available in extra long (XL) or low ground pressure (LGP) configurations. XL undercarriage provides increased ground contact area and flotation, superior balance and excellent finish grading. In addition, the LGP version also features a wider track shoe, increasing ground contact area for optimum flotation and stability on sloping and finish grading jobs.



SystemOne Cartridge



SystemOne Center Tread Idler

# AccuGrade™ Systems

Grade with increased accuracy.

Caterpillar is revolutionizing the way to move material with new technology solutions for earthmoving machines – solutions that provide greater accuracy, higher productivity, lower operating costs and greater profits. The AccuGrade System is designed and integrated into the machine and hydraulic systems to create an automated blade control system that allows operators to grade with increased accuracy. The system uses machine-mounted sensors to calculate precise blade slope and elevation information.

## AccuGrade Laser

AccuGrade Laser uses a laser transmitter and receiver for precise grade control. A laser transmitter on the worksite creates a constant grade reference over the work area. A digital laser receiver mounted on the machine captures the laser signal. The system calculates the blade adjustments necessary to achieve grade, makes automatic elevation adjustments typically performed by the operator and provides automatic blade control. The operator simply steers the machine. Automated blade control lets you achieve grade faster and in fewer passes, reducing the need for traditional survey stakes or grade checkers. The system also calculates cut/fill requirements for manual blade control. Work is completed faster, more accurately and with less manpower. AccuGrade Laser is well suited for flat work such as concrete pads and driveways.

## AccuGrade GPS

AccuGrade GPS computes the machine positioning information and compares the position of the blade relative to the design plan. Information is provided to the operator via an in-cab display showing blade elevation, necessary cut/fill to achieve grade, blade position on the design surface and a graphical view of the design plan with machine location. AccuGrade GPS puts all the information the operator needs to complete the job in the cab for a greater level of control. Vertical and horizontal guidance tools visually guide the operator to the desired grade. Automated features allow the hydraulic system to automatically control blade adjustments to move the blade to grade. The operator simply uses the light bars to guide the machine for consistent, accurate grades and slopes, increasing productivity with less fatigue. AccuGrade GPS is best used for cut and contour jobs.

## AccuGrade Monitor

Caterpillar is the first to integrate this system and its monitor into the machine's dash for easy viewing during operation. The AccuGrade monitor is conveniently located, allowing the operator to view system information while keeping a straight line of sight to the blade corners.



*AccuGrade Laser Display*



*AccuGrade GPS Display*

# Blade and Attachments

Cat work tools can handle tough dozing applications.



## VPAT Blade

The VPAT blade is specifically designed for finish grading, backfilling ditches, cutting V ditches, windrowing, fill spreading, medium land clearing and heavy dozing. Built for rugged strength and durability, this 6-way blade allows for adjustable angle, tilt and pitch. Visibility to the blade corners and cutting edge is improved. This is especially critical when working near curbs and foundation structures.

## Parallelogram Ripper

The aggressive parallelogram ripper lets you do more productive ripper work. The parallel linkage design provides better penetration and maneuverability in tight working areas.

## Forestry Options

An easier way to work in the woods. The D3K, D4K and D5K is available with the following features to aid in forestry applications:

- Forestry blade, featuring additional guarding to protect the tractor from debris and to provide increased productivity.
- Cat hydrostatic winch, featuring excellent line pull at any speed and infinitely variable drum speed.
- 360 degree guarding, for added protection of the cab.
- Heavy-duty rear tank guard.



# Hydrostatic Winch

Infinitely variable speed control.

The Cat hydrostatic winch offers outstanding control of the load with infinitely variable modulation of speed and pull. Mechanical winches force the operator to choose the gear ratio of the winch. The Cat hydrostatic winch eliminates this compromise by providing the speed of a standard winch and the pull of a low speed winch, all in one package.

The result is:

- Excellent line pull at any speed
- Infinitely variable drum speed
- Lower operator effort
- Unmatched load control



# Serviceability

Easy access and minimal maintenance requirements keep your machine on the job.



## Easy Access

Long service intervals and easy maintenance keep the machine up and running and lower your owning and operating costs. A large, hinged door on the left side of the engine compartment provides easy access to all regular engine maintenance points, including engine fuel filters and water separator, the engine oil filter, the engine oil dipstick and filler, the fuel priming pump and the engine air pre-cleaner and filters. Grouped pressure taps allow for quick testing and troubleshooting of the hydraulic system. The hydraulic filters are all located in the left rear service compartment and are accessible from ground level.

## Product Link

The optional Product Link system simplifies equipment fleet tracking. Using satellite or cellular technology, the system automatically reports information such as location, machine hours, active and logged service codes and security alarms.

## Machine Security System

An optional Machine Security System (MSS) that utilizes a programmable key system that deters theft, vandalism and unauthorized usage. MSS uses electronically coded keys selected by the customer to limit usage by individuals or time parameters.

# Customer Support

Unmatched support makes the difference.

**Your Cat dealer is ready to assist you with your purchase decision and everything after.**

- Make comparisons of machines, with estimates of component life, preventative maintenance and cost of production.
- Financing packages are flexible to meet your needs.
- Your Cat dealer can evaluate the cost to repair, rebuild and replace your machine, so you can make the right choice.
- For more information on Cat products, dealer services and industry solutions, visit us at [www.cat.com](http://www.cat.com).



# D3K, D4K and D5K Track-Type Tractor Specifications

## Engine

Engine Model Cat® C4.4 ACERT™

	D3K	D4K	D5K
Power – Gross	60.5 kW/ 82 hp	68.5 kW/ 93 hp	74.5kW/ 101 hp
Power – Net			
ISO 9249	55.2 kW/ 75 hp	62.6 kW/ 85 hp	71.6kW/ 97 hp
EEC 80/1269	55.2 kW/ 75 hp	62.6 kW/ 85 hp	71.6kW/ 97 hp
Displacement	4400 cm <sup>3</sup>	4400 cm <sup>3</sup>	4400 cm <sup>3</sup>
Bore	105 mm	105 mm	105mm
Stroke	127 mm	127 mm	127mm

- Net Power ratings are tested at the reference conditions for the specified standard.
- Ratings at 1900 rpm.
- Net power advertised is the power available at the flywheel when engine is equipped with fan, air cleaner, muffler and alternator.
- No derating required up to 3000 m altitude.

## Weights

	D3K	D4K	D5K
Operating weight – XL	7795 kg	8147 kg	9408 kg
Operating weight – LGP	8093 kg	8501 kg	9683 kg

- Operating with dozer blade, canopy ROPS, back-up alarm, operator, coolant, lubricants and full fuel tank.

## Ripper

Type: Parallelogram

	D3K	D4K	D5K
Number of shanks	3	3	3
Maximum digging depth			
	337.5 mm	337.5 mm	337.5 mm
Maximum reach at ground line	596 mm	596 mm	555 mm
Maximum ground clearance under tip	448 mm	448 mm	448 mm
Overall width	1710 mm	1710 mm	1710 mm
Height	165 mm	165 mm	165 mm
Weight	554 kg	554 kg	554 kg

## Drawbar

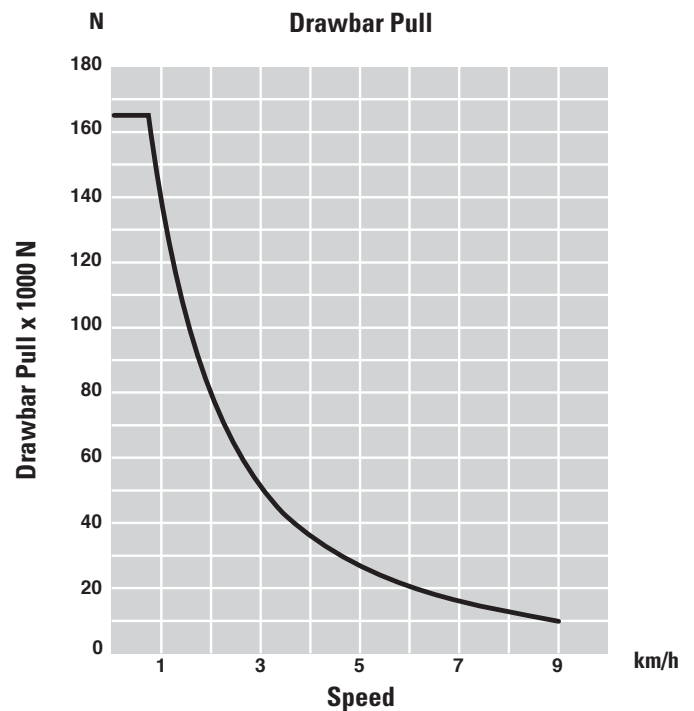

## Undercarriage

	D3K	D4K	D5K
Number of rollers (each side)	6	7	7
Number of shoes (each side)			
SALT (Sealed and Lubricated Track) Undercarriage	41	43	40
SystemOne Undercarriage	36	38	36
Shoe width			
XL	406 mm	460 mm	510 mm
LGP	635 mm	635 mm	660 mm
Length of track on ground			
XL	2095 mm	2248 mm	2310 mm
LGP	2095 mm	2248 mm	2310 mm
Track gauge			
XL	1495 mm	1550 mm	1600 mm
LGP	1725 mm	1725 mm	1750 mm
Ground contact area			
XL	17 011 cm <sup>2</sup>	20 682 cm <sup>2</sup>	23 562 cm <sup>2</sup>
LGP	26 697 cm <sup>2</sup>	28 550 cm <sup>2</sup>	30 492 cm <sup>2</sup>
Ground pressure			
XL	0.45 bar	0.39 bar	0.39 bar
LGP	0.30 bar	0.29 bar	0.31 bar

- Hydraulic track adjusters.
- Box section track roller frames.
- Bolt-on rear track guiding guards.
- Full length recoil guarding with sprocket guards and wipers.
- Serrated, two-piece split master link (SALT).
- Single-grouser shoes.
- Segmented sprocket (SALT).
- Sealed and lubricated rollers and idlers.

## Standards

### ROPS

ISO 3471-94, ISO 3164-95

### FOPS

ISO 3449-92

## Winch

	D3K	D4K	D5K
Weight	610 kg	610 kg	610 kg
Winch drive	Hydrostatic	Hydrostatic	Hydrostatic
Control	Hydraulic	Hydraulic	Hydraulic
Speed	Variable	Variable	Variable
Winch length	705 mm	705 mm	705 mm
Overall width	741 mm	741 mm	741 mm
Drum diameter	254 mm	254 mm	254 mm
Drum width	274 mm	274 mm	274 mm
Throat clearance	171.5 mm	171.5 mm	171.5 mm
Rope diameter			
recommended	16 mm	16 mm	16 mm
optional	19 mm	19 mm	19 mm
Drum capacity			
recommended cable	113 m	113 m	113 m
optional cable	78 m	78 m	78 m
Maximum line pull			
bare drum	18 144 kg	18 144 kg	18 144 kg
full drum	11 340 kg	11 340 kg	11 340 kg
Maximum line m/minspeed			
bare drum	40 m/min	40 m/min	40 m/min
full drum	63 m/min	63 m/min	63 m/min

- Infinitely variable line speed and line pull from 0 to maximum.
- Power in/power out, brake off, free spool (standard equipment).
- Single lever, low effort hydraulic control.
- Precise load control and speed modulation.
- Integral mounted drawbar.
- 3 roller fairlead available. Kit available to add a 4th roller.

# D3K, D4K and D5K Track-Type Tractor Specifications

## Transmission

All Models	
Drive pumps	2
Track motors	2
Relief valve settings	476 bar
Maximum travel speed	
forward	9 km/h
reverse	10 km/h

- Dual-path, closed loop hydrostatic drive provides infinitely variable speeds from 0-9 km/h forward and 0-10 km/h reverse.
- Full-flow filtering of hydrostatic charge system oil.
- Drive pumps: two variable-displacement, slipper-axial piston pumps mounted tandem-style to engine flywheel housing.
- Track motors: two variable-displacement, link-type piston motors.

## Service Refill Capacities

All Models	liter
Fuel tank	195
Crankcase and filter	11
Final drives, XL (each side)	10
Final drives, LGP (each side)	10
Cooling system	22.4
Transmission/hydraulic tank	59.5

## Hydraulic Controls

Pump output	73.5 l/min
Relief valve setting	206 bar

- Pump output ratings at 2150 rpm and 69 bar.
- Control positions:
  - Lift cylinders – raise, hold, lower, float.
  - Tilt cylinders – left, hold, right.
  - Angle cylinders – left, hold, right.
  - Ripper cylinders – raise, hold, lower.

## Final Drive

Features:

- Double-reduction planetary gear set.
- Mounted independently of track frames to isolate them from machine weight and ground-induced shock loads.

## Steering and Braking

Features:

- Full powerturn.
- Counterrotation.
- Single lever steering, speed and direction control.
- Hydrostatic (dynamic) braking through machine drive system using transmission control lever, center brake pedal or decel pedal.

## Dimensions

All dimensions are approximate.

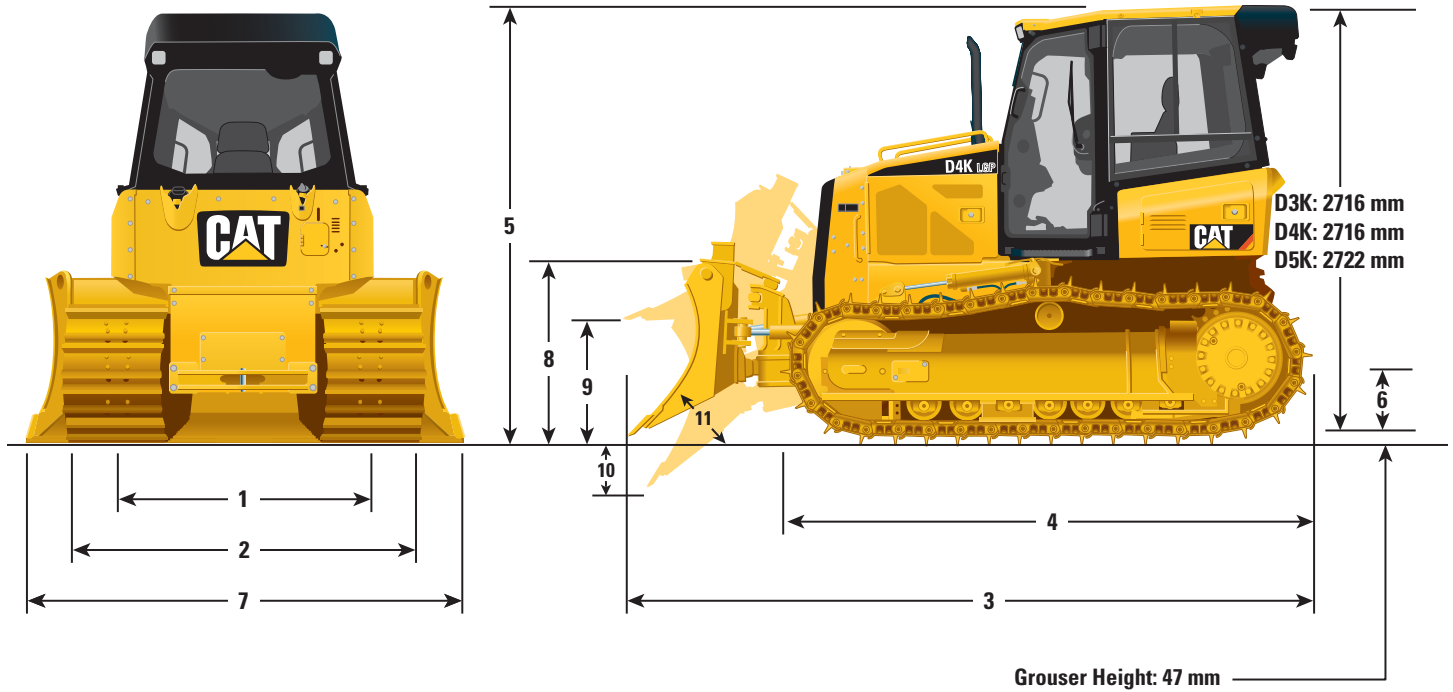

	D3K		D4K		D5K	
	XL	LGP	KL	LGP	XL	LGP
	mm	mm	mm	mm	mm	mm
<b>1</b> Track gauge	1495	1725	1550	1725	1600	1750
<b>2</b> Width of tractor (std shoes, no blade)	1902	2360	2010	2360	2110	2410
<b>3</b> Overall length (with blade)	4266	4255	4274	4266	4321	4294
<b>4</b> Length of basic tractor (without blade)	3275	3275	3275	3275	3265	3265
<b>5</b> Tractor height	2763	2763	2763	2763	2769	2769
<b>6</b> Ground clearance	332	332	332	332	332	332

Blade	XL	*	LGP	XL	*	LGP	XL	*	LGP
	mm	mm	mm	mm	mm	mm	mm	mm	mm
<b>7</b> Blade width	2646	2921	3149	2782	2921	3149	2886	2921	3220
<b>8</b> Blade height	910	860	860	1010	860	910	1050	1010	1010
<b>9</b> Blade lift height	730	743	730	743	743	708	767	767	787
<b>10</b> Digging depth	573	573	573	573	590	590	586	572	572
<b>11</b> Blade cutting edge angle, adjustable	52-58°	52-58°	52-58°	52-58°	52-58°	52-58°	52-58°	52-58°	52-58°
Maximum tilt	387	448	438	387	448	438	402	448	448
Maximum angle (either side)	25°	25°	25°	25°	25°	25°	25°	25°	25°
Blade width at maximum angle	2417	2669	2874	2542	2669	2874	2636	2669	2940
Blade capacity (SAE)	1.52 m <sup>3</sup>	1.50 m <sup>3</sup>	1.66 m <sup>3</sup>	1.98 m <sup>3</sup>	1.50 m <sup>3</sup>	1.85 m <sup>3</sup>	2.09 m <sup>3</sup>	1.50 m <sup>3</sup>	2.34 m <sup>3</sup>

\* Intermediate

# D3K, D4K and D5K Standard Equipment

Standard equipment may vary. Consult your Caterpillar dealer for details

## ELECTRICAL

Horn  
Backup alarm  
Diagnostic connector  
Heavy duty 750 CCA batteries  
Alternator, 12 V, 120 Amp, heavy duty brushless  
12 V Starter

## OPERATOR ENVIRONMENT

ROPS/FOPS cab with sliding side windows and air conditioning  
Cat C500 comfort cloth air suspended seat with adjustable armrests  
76 mm retractable seat belt  
Adjustable seat-mounted, electro-hydraulic controls  
Foot rests  
Compact Instrument Cluster including:

- Gauges for engine coolant temperature, hydraulic oil temperature and fuel level
- 12 indicators
- Digital display (ground speed, engine RPM, hour meter)

Rotary throttle switch  
Travel speed limiter  
Independent forward/reverse speed settings  
Single pedal combining deceleration and braking functions  
Rearview mirror  
12 V power port  
Coat hook  
Storage compartment  
Cup holder  
Heavy duty rubber floor mat  
Windshield washers and wipers, front and rear

## POWER TRAIN

Caterpillar C4.4 ACERT diesel engine, turbocharged  
Aluminum bar plate cooling system (radiator, power train)  
Blower fan  
Air cleaner with precleaner, automatic dust ejection and under-hood intake  
Fuel priming pump with integrated fuel/water separator  
Dual path, closed-loop hydrostatic transmission  
Under-hood muffler

## HYDRAULICS

Hydraulics, 3 valve

## UNDERCARRIAGE

SALT Undercarriage  
Lifetime lubricated track rollers and idlers  
Carrier rollers  
D3K: Tracks, 41 sections;

- XL configuration 406 mm
- LGP configuration 635 mm

D4K: Tracks, 43 sections:

- XL configuration 457 mm
- LGP configuration 635 mm

D5K: Tracks, 40 sections:

- XL configuration 510 mm
- LGP configuration 660 mm

Hydraulic track adjusters

## OTHER STANDARD EQUIPMENT

C-Frame, VPAT, hydraulic cylinders and lines  
Fuel tank  
Heavy duty crankcase guard  
Lockable engine enclosures  
Idler guards  
Radiator guard and grill  
Front pull device  
Rigid drawbar  
S•O•S<sup>SM</sup> ports (engine, power train and hydraulics)

## ANTIFREEZE

Extended life coolant, -37° C

# D3K, D4K and D5K Optional Equipment

Optional equipment may vary. Consult your Caterpillar dealer for details.

## ELECTRICAL

Integrated two front halogen lights, one rear halogen light

Integrated four front halogen lights, two rear halogen lights

## POWER TRAIN

Drive auxiliary

Installation, winch

## UNDERCARRIAGE

D3K:

TRACK PAIRS, XL

- Track 406 mm MS SystemOne™
- Tracj 356 mm TG SALT

TRACK PAIRS, LGP

- Track, 635 mm MS SytemOne™
- Track, 635 mm Self Cleaning SALT
- Track, 635 mm, SystemOne™

D4K:

TRACK PAIRS, XL

- Track, 457 mm MS SystemOne™

TRACK PAIRS, LGP

- Track, 635 mm (25 in) MS SystemOne™

D5K:

TRACK PAIRS, XL

- Track, 510 mm MS System One™

TRACK PAIRS, LGP

- Track 660 mm MS System One™
- Track, 760 mm MS System One™

## OPERATOR ENVIRONMENT

Cab

Cab, polycarbonate windows, 360 degree guarding protection

Seat, cloth, air suspension, heated

Radio, AM/FM, CD player

## HYDRAULICS

Hydraulics, 4 valve for use with ripper

Hydraulics, 4 valve for use with winch

## GUARDS

Guard, rear, heavy duty

Grill, radiator, heavy duty

Guard, track guiding, center

Guard, track guiding, full length

Screen, rear, cab

Screen, side, cab

Screen, rear, canopy

Screen, front and sides, canopy

Sweeps, front

Sweeps, rear

## BLADES

VPAT XL blade

VPAT LGP blade

VPAT Intermediate blade

## REAR ATTACHMENTS

Drawbar, towing

Mounting, winch

Ripper, parallelogram, includes three shanks and teeth

## REAR ATTACHMENT CONTROL

Control, ripper

Control, winch

Control, ripper and winch

## MACHINE CONTROL AND GUIDANCE

Installation, AccuGrade ready

## STARTING AIDS

Heater, engine, coolant, 120V

Starting aid, ether

## OTHER ATTACHMENTS

Enclosure, sound suppression

Machine Security System

Caterpillar Product Link 321

Caterpillar Product Link 121

## ANTIFREEZE

Coolant, ext. life, -50° C

## FIELD INSTALLED ATTACHMENT

Winch, hydrostatic

# D3K, D4K and D5K Track-Type Tractors

For more complete information on Cat products, dealer services, and industry solutions, visit us on the web at [www.cat.com](http://www.cat.com)

HEHT3780 (03/2008) hr

Materials and specifications are subject to change without notice. Featured machines in photos may include additional equipment. See your Caterpillar dealer for available options.

© 2007 Caterpillar -- All rights reserved

CAT, CATERPILLAR, their respective logos, "Caterpillar Yellow" and the POWER EDGE trade dress as well as corporate and product identity used herein, are trademarks of Caterpillar and may not be used without permission.

**CATERPILLAR**<sup>®</sup>