

432E

Backhoe Loader

CATERPILLAR®



Cat® 3054C DIT Diesel Engine

	Standard	Optional
Gross power (SAE J1995) at 2200 rpm	68.5 kW/93 hp	74.5 kW/101 hp
Net Power (ISO 9249) at 2200 rpm	65 kW/89 hp	71 kW/97 hp

Cat® C4.4 Turbocharged After cooled Engine

Gross power (SAE J1995) at 2200 rpm	70 kW/95 hp	74.5 kW/101 hp
Net Power (ISO 9249) at 2200 rpm	67 kW/91 hp	71 kW/97 hp
Operating Weight		7780-10700 kg

Backhoe Digging Depth

Standard Stick	
SAE Maximum	4422 mm
Maximum	5022 mm
Extendable Stick	
SAE Maximum	5294 mm
Maximum	5840 mm

432E Features

Versatility

Being easily adaptable to work with a variety of Cat Work Tools ensures high machine utilization on any working site.

Performance

Class leading all round performance and ease of operation ensures high levels of efficiency and maximum productivity.

Comfortable Operator Station

Spacious and quiet, this world-class environment enables the operator to productively focus on the task at hand with the minimum of effort.

Service

Caterpillar's principles of design and manufacturing techniques provide maximum uptime with outstanding durability and service life.

Value

With excellent performance, reliability, durability, quality and residual values the Cat Backhoe Loader provides the owner with a prudent investment decision.



Contents

Features	3
Work Station	4
Operator Comfort	5
Pilot Operated Joystick Controls	6
Loader Versatility	7
Backhoe Performance.....	8
Hydraulics	9
Work Tools	10
Power Train	11
Serviceability.....	12
Customer Support.....	12
Specifications	12
Standard and Optional Equipment.....	18

Caterpillar's 432E – A highly productive Backhoe Loader developed with over 20 years experience in the Backhoe Loader industry, the 432E is designed to exceed customer expectations. More performance, versatility and comfort than ever before gives the 432E the edge needed in a harsh and competitive environment.

Along with you, it's up to the challenge. See your Cat dealer and try out The Next Generation of Backhoe Loaders from Caterpillar.

Features

Customer driven improvements are designed into the 432E.



Low Operating Costs

The 432E has an adjustment system that is simple to adjust ensuring easy maintenance of the Stabilizer and E-Stick a wear pads. This means less machine downtime and more convenience for the operator providing low operating costs.

All Wheel Braking

All Wheel Braking is standard on all 432E Backhoe loaders. When driving in two wheel drive, applying the brakes engages four wheel drive. Releasing the brakes returns the transmission to two wheel drive. This effective system works well in hazardous, slippery or steep surfaces. Braking modes are controlled by an easily accessible All Wheel Drive Switch improving braking effectiveness and helps reduce tire wear.

Improved Weight Distribution

The 432E has been designed with a long wheel base to ensure optimum balance and handling, particularly when roading. This is achieved with no loss in turning circle.

Large Fuel Tank

Responding to customer needs, a large 160 liter fuel tank, along with the efficient Cat engine and hydraulic system, ensures longer periods between fill ups and less inconvenience.

Cat Immobilizer System

Machine theft has serious repercussions for your business, such as loss of business, higher insurance costs and inconvenience. The Cat Immobilizer System is a diesel engine immobilizer system, designed to provide theft protection. The system meets Thatcham approval and PTAG attack time requirements and a premium discount may be available from certain Insurance companies (see your Cat dealer for details). The system uses the same key but has a one touch pad for easy disarming.

Electro-Deposition Coating

Your 432E has been protected by an undercoat of electro deposited (E-Coat) primer, which completely seals each metallic component and offers a superlative degree of protection from damage and corrosion. Coupled with the high solids polyurethane top coat, your 432E will stay looking good for longer, ensuring optimum resale value.





Work Station

The E-series cab. Comfort, visibility, Style - Designed In!

The 432E Cab is designed with today's Operator in mind. The E-Series cab is designed to provide maximum comfort, ease of operation and with modern styling meets the requirements of today's demanding operator. The design incorporates curved glass for improved interior space and visibility. A wide cab provides a spacious environment for better performance when turning the seat from one mode of operation to the other. Cab comfort is enhanced with the first-class Cat air suspension seat, reducing fatigue.

An easy to open single rear piece window provides the operator with excellent ventilation and superb visibility. The rear wiper easily cleans a large area of the rear screen to ensure excellent visibility of the working area when working in wet or dusty conditions.

Excellent ergonomics ensure that all controls are within easy reach of the operator, and tinted glass is standard in all cabs.

Other features such as remote stabilizer controls, large adjustable vents throughout the cab, and clear gauges provide the operator with a comfortable operating environment designed to reduce operator fatigue and increase productivity.

Operator Comfort

The working environment has been designed with the operator in mind.

Vibration

Caterpillar understands that backhoe loaders work in some of the harshest environments. By controlling normal machine vibrations caused by these harsh conditions, operator efficiency and productivity are improved. The 432E has features, both standard and optional, that reduce vibration.

Operator Controls

Optimal cab ergonomics are vital to assist the operator in their quest for best productivity. Pressure compensated, well placed levers ensure low efforts and good controllability for maximum productivity.

HVAC System

The 432E benefits from an optional, powerful air conditioning system, which with good ventilation to the operator, ensures the operator stays cool in the highest of working temperatures. The ventilation system also provides plenty of demisting, defrosting and heating capability.

Work Lights

The 432E has adjustable front and rear work lights. This allows the operator to direct the light wherever needed, providing maximum illumination to the work area whatever the ambient light conditions.

Cab Air Filter

The 432E has an easy access cab air filter, situated within the right hand rear fender. The cab air intake is positioned high up to minimize dust intake into the air filter.

Cab

The 432E is available in 2 cab options, providing the best choices to suit individual operator needs.

Cab Mounts

The cab is attached to the mainframe with resilient mounts, reducing vibration and sound providing the operator with an all round comfortable working environment.

Cat Suspension Seat

The major interface between the machine and the operator is optimal, and the Cat air suspension seat provides the operator with a comfortable working platform to ensure high levels of productivity with the minimum of fatigue.





Pilot Operated Joystick Controls

Standard on the 432E, Pilot controls reduce fatigue, improved visibility and increase versatility.

Joystick Controls

Excavator style joystick controls provide smooth modulation and are ergonomically designed for low effort control maximizing operator comfort. The location of the controls naturally positions the operator in to the most comfortable of operating positions. Proportional controls in both the loader and the excavator hoe joysticks give precise control of loader and excavator worktools and extendable stick.

Excavator Control Pattern Changer

The 432E has an in-cab backhoe control pattern changer as standard, allowing operators to choose between either ISO, or SAE control patterns. Conveniently located within reach of the operator the operator can easily select a preferred operating control pattern.

Stabilizer Controls

Pilot operated, conveniently located stabilizer controls are available with optional Auto-Up feature, reducing cycle times and improving visibility to the rear.

Multi Position Joystick Pods

The joysticks are pod-mounted, with two location positions, fore and aft for the controls. This allows the operator to move forward when excavating close to the rear of the machine, and have a clear view to the trench.

Visibility

With no centrally mounted control console impeding vision, the operator has an unobstructed view to the working area.

Loader Versatility

The 432E Parallel Lift Loader now has even greater performance.



Powerful Loader Performance

The 432E Parallel Lift Loader offers self levelling as standard, ensuring faster loading cycles. Designed with performance in mind the 432E has high breakout forces enabling the operator to easily fill the bucket in toughest of ground conditions whilst also providing safe lifting of any palletized load. Available with either a General Purpose or Multi Purpose bucket, the 432E can be matched to your needs precisely. Work tool visibility is excellent with the narrow sloping hood and divergent loader arms allowing a clear line of sight to the bucket edges. A large torque tube provides torsional stiffness, needed when grading or picking up irregular shaped heavy objects with the loader bucket.

Joystick Control

The loader joystick is ergonomically placed for operator comfort, and controls the multi-purpose bucket and auxiliary hydraulics when these options are fitted.

Ride Control

Caterpillar's proven Ride Control system is an option designed to reduce machine pitching and bouncing giving operators a smooth ride in all applications, including load and carry, roading, or simply moving around the jobsite. An accumulator acts as a shock absorber to reduce machine pitching and provide a smoother ride over rough terrain. The system is engaged by a switch on the front console.

Return to Dig

Your 432E is equipped with a standard Return to Dig system. This system reduces loading cycle times by bringing the loader bucket back to the dig position automatically when lowering the arms. By the time the loader arms have been lowered to ground level, the bucket is in the correct position ready for the next load.

Hydraulic Quick Coupler Option

The 432E is available with an optional quick coupler, allowing greater loader versatility with a wide range of Cat work tools increasing machine utilization on any work site.



Backhoe Performance

The E-Series Backhoe improves performance and serviceability.

Excavator-style Backhoe

The Cat excavator style boom has more than just good looks. Whether close-up truck loading on a single road carriageway, or digging over obstacles such as walls, the excavator boom outperforms the rest. Combine the versatility with the powerful breakout forces, the controllability of the load sensing, flow-sharing hydraulic system and the 432E is capable of producing high levels of productivity with the minimum of operator effort. The boom is a narrow design, ensuring maximum visibility to the work tool.

Performance

Designed with performance in mind the 432E excavator has high stick and bucket breakout forces enabling the operator to easily dig in toughest of ground conditions.

Extendable Stick

The 432E is available with an extendable stick that increases dig depth and reach capability increasing the machines versatility and utilisation.

A sliding inner section design keeps the wear pads out of the dirt, extending adjustment and replacement intervals. When wear pad adjustment is necessary the adjustment bolts are easy to access taking minutes to adjust, without the need to disassemble the E-Stick. Auxiliary lines, for operating worktools, have been routed so that they are protected from damage when working in the narrowest of trenches.

Hydraulics

Load sensing, flow-sharing system matches power and flow supply to demand – where you need it, when you need it.



Flow Sharing Valves

The 432E also features flow-sharing hydraulic valves, ensuring the correct flow of oil reaches the implement cylinders, providing greater control and eliminating oil starvation when operating multiple functions.

Hardware

The 432E is equipped with a highly efficient variable displacement piston pump. The reliable high performance hydraulic hose is constructed from two strong steel braided layers and O-ring face seal fittings provide a robust system ensuring excellent durability and resistance to damage from pressure spikes and hydraulic pulsing.

Hydraulic Performance

It's rare that you'll be working at full production 100% of the time, so why should the machine be working flat out, using more fuel, making more noise, and increasing wear? The 432E has a load-sensing, closed center hydraulic system, which closely matches power and flow to the demand needed by the implements. So whether you're in full trenching mode, or delicately digging around services, you are in control.

In applications such as loading and carrying, speed is important, and system will match the flow needed to get the job done quickly and efficiently. As there is minimal demand on the system unless needed, there are less parasitic losses and more power available for rimpull – providing better loading and roading.

Work Tools

Enhance the versatility of your 432E, with a wide choice of tools on offer to suit your needs.



Backhoe Buckets

Caterpillar offers a huge variety of hoe buckets to meet your requirements, including:

- Standard Duty Bucket. Used in easy to penetrate, low impact, moderately abrasive materials.
- Heavy Duty Bucket. Used for digging fragmented rock, frozen ground and highly abrasive materials.
- Extreme Service Bucket. Used in highly abrasive, high impact soil.
- High Capacity Bucket. Same durable construction as the HD bucket, but longer tip radius provides increased fill capacity.

Durability

Cat backhoe buckets offer superior durability with the following features:

- Thick cutting edges.
- DRS (Diagonal Retention System) ensures easier replacement of pin on teeth and greater strength.
- Thick wear material on the side plates for better reinforcement and less wear.
- ID plates on all buckets showing part number, GET sizes and machine compatibility.

Sizes

Work tools are available in a full range of sizes, from a 9"/228 mm Cribbing bucket for cable trenching, a range of Ditch Cleaning buckets, right up to large capacity 36"/914 mm buckets for mass excavation.

Quick coupler - Loader and Hoe

A hydraulic quick coupler is available for the Loader, and a mechanical quick coupler option is available for the Hoe. For operators who require fast tool changes, both quick coupler options can save a lot of time, money and effort.

Hydro-Mechanical Work Tools

Caterpillar has designed a range of hydro-mechanical tools carefully matched to the machine for optimum performance,

including:

Hoe

- H65 Hydraulic Hammer
- Auger
- Vibratory Plate Compactor
- Cold Planer

Loader

- Angle Broom
- Pickup Sweeper



Power Train

432E has a 40 kph transmission as standard - less time on the road, more time on the job site.

40 kph Power-Shuttle Transmission

The 432E comes equipped with 40 kph Power-Shuttle transmission, improving roading speed and providing better spacing between gear ratios. It utilizes a constant mesh, synchronized, four speed system. The forward/reverse lever on the steering column is placed for easy direction changes on the move, and the gear selection is from the floor mounted shift lever.

Cat Engine

The 432E is available with either the 3054C turbocharged engine that meets Stage II emission regulation EU Directive 97/68/EC or the C4.4 turbocharged After cooled engine that meets Stage IIIA EU emission Directive 2004/26/EC. A choice of power rating enables the performance of the machine to be matched to customer requirements. All engines are reliable 4 cylinder, 4 stroke direct injection diesel engines equipped with standard glow plug starting for optimum cold weather performance. This provides reliable starting performance down to -18 C. All engines feature a reliable gear driven water pump and a durable poly vee front end auxiliary drive belt that is automatically tensioned for longer life reducing operating costs.

Air Filter

A dry type axial air cleaner with an integral pre-cleaner and automatic integrated dust ejection system extends the life of the air filter when working in dusty conditions reducing service time and costs.

Axles and Brakes

The heavy duty Cat rear axle is an enclosed design with a wet multiplate Kevlar braking system. This system is oil immersed and self adjusting, and allows operation in the harshest environments. The system has dual brake pedals for split braking in tight corners.

Optional Auto-Shift Transmission

Work faster with the optional Auto-Shift transmission. The Auto-Shift transmission provides automatic shifting between five forward and three reverse gears. There is no floor mounted shift lever, so the operator has more floor space and better access through the right hand door.

Diff-Lock

A manually operated differential lock in the rear axle is fitted as standard providing maximum traction on adverse ground conditions.

Serviceability

Lower operating costs mean a better return on your asset.

Reduced Maintenance

The 432E is equipped with a flip open hood, allowing access to all check/fill points, air cleaner, washer bottles, visual indicators etc. The E-Series carries on the tradition with sealed for life axle oscillation, driveshaft universal joints, trunnions etc. Daily maintenance, which can be a chore for the busy operator, is kept to a minimum on the 432E.

Boom and Stick Design

The Boom and Stick design allows all wear adjustment to be done with Stick in-situ, using a simple wedge adjustment mechanism - no dismantling required. The Stabiliser legs are also externally adjustable, reducing machine down time and inconvenience.

Cat Filters

All Cat filters are vertically mounted for spill free servicing and reduced oil contamination. They are also low micron filters, filtering even the tiny particles from the oil and keeping the engine, transmission and hydraulic system running smoothly for years.

Scheduled Oil Sampling

Your Cat dealer will be able to provide the Caterpillar S•O•SSM. This enables your dealer to analyze wear before problems arise, so that premature failure can be avoided, and corrective action can take place to reduce costs and downtime.



Customer Support

Low operating costs with your dealers excellent services and options.

Customer Support Agreements (CSA's)

Your Cat dealer can offer a comprehensive range of CSA's which can be individually tailored to suit your finances and requirements. Dealers can offer a range of options from a full Preventative Maintenance with S•O•S package to a Parts Only CSA. Protect your valuable investment and know exactly what your monthly payments will be to help you run your business.

Finance

Have you explored the range of options available from your dealer to finance your machine? They can offer a selection of attractive packages tailored exactly to your requirements.

Machine Selection

Your dealer can help guide you with your machine purchase decision, based on your requirements and help keep operating costs to a minimum. Is the machine you have in mind exactly the best for your job, or could other attachments be more suitable?

Operating Techniques

Your dealer can advise operating techniques for your machine which will minimize wear and tear, maximize productivity, and lower owning and operating costs.

Remanufactured components (Reman)

Sometimes, the most cost effective way to repair the machine is with remanufactured components. Reman components are rebuilt to original specification at a Cat Reman facility, using genuine parts and skilled technicians. Reman parts are guaranteed for 1 year.



432E Specifications

Engine	Cat 3045C*	Cat C4.4**
Rated Power (standard)	2200 rpm	2200 rpm
Gross – SAE J1995	68.5 kW/93 hp	70 kW/95 hp
Net – ISO 9249	65 kW/89 hp	67 kW/91 hp
Net – 80/1269/EEC	65 kW/89 hp	67 kW/91 hp
Rated Power (optional)	2200 rpm	2200 rpm
Gross – SAE J1995	74.5 kW/101 hp	74.5 kW/101 hp
Net – ISO 9249	71 kW/97 hp	71 kW/97 hp
Net – 80/1269/EEC	71 kW/97 hp	71 kW/97 hp
Net Torque Rise at 1400 rpm		
70 kW/95 hp	-	30%
68.5 kw/93 hp	33%	-
74.5 kW/101 hp	26%	23%
Peak Torque Rise at 1400 rpm		
70 kw/95 hp	-	395 Nm
68.5 kW/93 hp	395 Nm	-
74.5 kw/101 hp	408 Nm	400 Nm
Bore	105 mm	105 mm
Stroke	127 mm	127 mm
Displacement	4.4 liter	4.4 liter

- All engine horsepower (hp) are metric including front page.
- Net power advertised is the power available at the fly wheel when the engine is equipped with fan, air cleaner, muffler and alternator.
- Can be operated at maximum altitude of 3000m

* Stage II EU Emission Directive 97/68/EC

** Stage IIIA EU Emission Directive 2004/26/EC

Axles

Features

- Heavy-duty rear axle with self adjusting inboard brakes, differential lock, standard All Wheel Drive (AWD) and final drives.
- AWD is engaged by front console panel switch or by brake pedal during all-wheel-braking operation. AWD can be engaged on-the-go, under load, in any gear, forward or reverse. AWD has outer final drives for easy maintenance.
- AWD front axle is pendulum mounted and permanently sealed and lubricated, requiring no daily maintenance. Also features double acting steering cylinder with 52° steering angle for increased manoeuvrability.

Features

- Three ring pistons made of lightweight silicon/aluminium alloy for strength and maximum thermal conductivity.
- Forged, chrome/molybdenum-steel crankshaft with nitro-carbonized journals.
- Front and rear crankshaft oil seals are 'lip' type Viton and PTFE designs featuring an integral dust lip.

Steering

Full hydrostatic steering controlled by a hand-metering unit. Secondary steering system available to meet roading regulations in various countries and to meet ISO 5010.

Type	Front wheel
Power Steering	Hydrostatic
Cylinder, one (1) double-acting (AWD)	
Bore	65 mm
Stroke	120 mm
Rod diameter	36 mm
Turning Circle	
Inner wheel not braked 4WD	
Outside front wheels	8180 mm
Outside widest loader bucket	10 800 mm

- Heat resistant silicon-chrome steel intake and STELLITE faced exhaust valves are used for long engine life.
- Cylinder block is high strength, cast iron alloy of deep-skirt, monobloc design for increased strength and long life.
- Poly vee front end and auxiliary drive belt that is automatically tensioned for long life reducing operating costs.
- Cylinder head is high strength, cast iron alloy construction with extra duty wall and head thickness. Intake and exhaust ports are precision cast to promote optimum gas flow.
- Direct injection fuel system provides accurate fuel delivery. Self priming electric lift pump for improved cold start capability. One filter fuel system for reduced maintenance costs.
- High torque at low engine speeds for better machine performance.
- Dry type, axial seal air cleaner with automatic, integrated dust ejection providing more efficient preseparation.
- Direct electric 12 volt starting and charging system with 750 CCA group 31 maintenance free battery.

Brakes

Fully enclosed, hydraulic, multiple discs.

Features

- Inboard oil-immersed, hydraulically actuated multiple Kevlar discs on final drive input shaft.
- Completely enclosed and sealed.
- Self-adjusting.
- Foot-operated brake pedals can be interlocked for roading.
- Parking/secondary brakes are independent of the service brake system. Parking brake is mechanically applied through a hand lever located in the right side console.

Meets ISO 3450:1996 requirements.

432E Specifications

Service Refill Capacities

	Liters
Cooling System	
without heater	23.0
with heater	25.0
Fuel tank	160.0
Engine with oil filter	7.6
Transmission (Power shuttle)	
Power Shuttle AWD	18.5
Rear Axle (Rigid/Steerable)	
Center Housing	16.5
Center Housing Additive	0.5
Wheel End/Final Drive (volume per side)	1.7
Front Axle AWD	
Center Housing	11.0
Wheel End/Final Drive (volume per side)	0.7
Hydraulic System (min/max)	79/99
Hydraulic Tank	40

Hydraulic System

Load-sensing, closed-center system.

Variable-flow, closed-center, load-sensing system provides full hydraulic force to cutting edges at all engine speeds. Provides low fuel consumption and low effort controls.

Type	
Closed-center	
Pump type	
Variable-flow, axial-piston	
Pump capacity	156 lpm at 2200 rpm
System pressure	249 bar

Transmission

The standard Power-shuttle transmission provides four speed forward and reverse, full synchromesh in all gears. Constant mesh gears on all ratios permit on the go shifting of all gears up or down. Neutral start provision prevent starting while shuttle is engaged. Torque converter free wheel clutch allows the converter stator free wheel during high speed, low load conditions such as roading.

Transmission disconnect

Hand operated power disconnect for easy, on-the-go shifting and full engine rpm when in the loading cycle.

Forward/Reverse electric power shuttle

Conveniently placed, hand operated lever provides instant direction changes between forward and reverse through power hydraulic clutches.

Torque converter

Single stage, 2.64 stall ratio

Travel Speeds

Travel speeds of All Wheel Drive back-hoe loader at full throttle, when equipped with 16.9 x 28 rear tires.

	Power Shuttle (standard)	Autoshift (optional)
Forward	kph	kph
1st	6	6
2nd	10	9
3rd	20	20
4th	40	27
5th	-	40
Reverse		
1st	6	6
2nd	10	12
3rd	20	26
4th	40	-

Operator Station

ROPS/FOPS is standard.

ROPS (Roll Over Protective Structure) offered by Caterpillar for this machine meets ROPS criteria ISO 3471:1994 and FOPS (Falling Objects Protective Structure) criteria ISO 3449:1992.

Weights

Standard single tilt loader, with
1.0 m3 general purpose loader bucket,
610 mm standard duty backhoe bucket,
80 kg operator and a full fuel tank.

	kg
Operating weight (range)	7780-10700
Standard machine weight	7952
ROPS canopy	-260
Autoshift	50
Air conditioning	48
Multi-purpose bucket 1.03 m3	
With fold-over forks	835
Without fold-over forks	700
Extendible stick (excludes front counterweight)	230
Counterweights	
Base	115
Stackables – One	235
Stackables – Max	485

Minimum Counterweight

Recommendations:

Standard Stick	
General Purpose	250
Multi Purpose	Base
Multi purpose with fold-over forks	Base
Extendible Stick	
General Purpose	485
Multi Purpose	235
Multi Purpose with fold-over forks	115

Cab Features

	Standard	Deluxe
RH opening door with opening window	√	√
LH opening door with opening window	√	√
2 rear side fixed windows	√	
2 rear side opening windows		√
Standard air suspension seat	√	
Deluxe air suspension seat		√
8 working lights	√	√
Floor mat	√	√
LH storage console	√	√
Tilt steering column	√	√
Exterior rear view mirror	√	√
Beacon socket (2)	√	√
Internal power socket	√	√
Radio ready headliner	√	√
Instrument cluster display gauge	√	√
Sun visor	√	√
Cat Contravision		√
Steering wheel knob	√	√
Vandal guard	√	√
Cab heater	√	√
Cab air conditioning		optional
Auto-Up Stabilizers		optional
Seat belt (50 mm)	√	√

432E Specifications

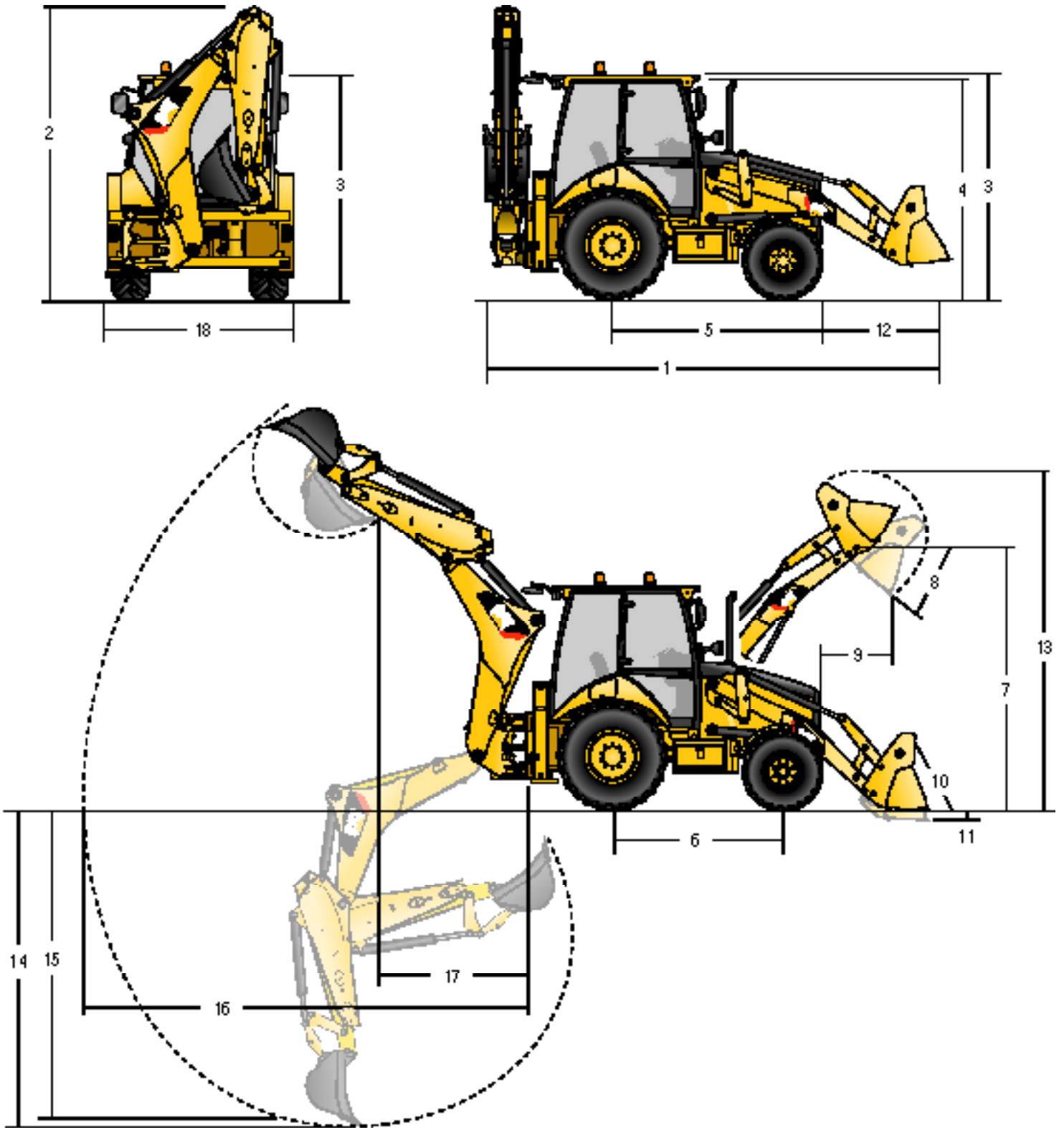

Machine Dimensions

		General Purpose	Multi Purpose	Multi Purpose with Forks
1	Overall length (loader on ground) S-Stick	mm	5810	5754
	Overall length (loader on ground) E-Stick	mm	5810	5754
	Overall transport length S-Stick	mm	5836	5811
	Overall transport length E-Stick	mm	5838	5813
2	Overall transport height S-Stick	mm	3736	3736
	Overall transport height E-Stick	mm	3759	3759
	Overall Width (Standard)	mm	2368	2368
	Overall Width (Narrow)	mm	2242	2242
3	Height to top of cab/canopy	mm	2863	2863
4	Height to top of exhaust stack	mm	2779	2779
	Height to loader hinge pin (transport)	mm	403	429
	Ground clearance (minimum)	mm	358	358
5	Rear axle centerline to front grill	mm	2704	2704
	Front wheel tread gauge	mm	1915	1915
	Rear wheel tread gauge	mm	1713	1713
6	Wheel based (AWD)	mm	2200	2200

Dimensions and Performance - Loader Bucket

		General Purpose	Multi Purpose	Multi Purpose with Forks
	Capacity (SAE rated)	m ³	1.0	1.03
	Width	mm	2406	2406
	Lift capacity at maximum height	kg	3322	2899
	Breakout force	kN	55	61
	Tipping load at bucket load point	kg	6217	6101
7	Maximum hinge pin height	mm	3340	3340
8	Dump angle at full height		45°	45°
	Dump height at maximum angle	mm	2634	2668
9	Dump reach at maximum angle	mm	794	724
10	Maximum bucket rollback at ground level		39°	40°
11	Digging depth	mm	91	118
	Maximum grading angle	mm	112°	115°
	Width of dozer cutting edge	mm	-	2406
12	Grill to bucket cutting edge, carry position	mm	1505	1480
13	Maximum operating height	mm	4238	4264
	Jaw open maximum	mm	-	790
	Bucket jaw clamping force	kN	-	61
	Weight (not including teeth)	kg	428	611

Dimensions and Performance - Backhoe

		Extendable Stick		
		Standard Stick	Retracted	Extended
14	Digging depth, SAE maximum	mm	4422	4301
	Digging depth, maximum	mm	5022	4899
15	Digging depth, 610 mm flat bottom, SAE maximum	mm	4379	4259
	Digging depth, 610 mm flat bottom, maximum	mm	4979	4857
16	Reach from swing pivot at ground line	mm	5667	5657
	Loading height	mm	3712	3914
17	Loading reach	mm	1827	1661
	Swing arc		180°	180°
	Bucket rotation		205°	205°
18	Stabilizer width	mm	2368	2368
	Bucket dig force	kN	63	63
	Stick dig force	kN	41	43
	Total side shift travel	mm	1258	1258

Standard Equipment

Standard equipment may vary. Consult your Cat dealer for details.

Air cleaner, dry type, axial seal with pre-cleaner and filter condition indicator	Front axle, pendulum mount	Mirrors, external (2)
All Wheel Drive	Front grill with bumpers	Pilot stabilizer controls
Alternator, 120-amp, 12 volt	Front headlights	Power receptacle, 12 V (2)
Antifreeze (to -37°C)	Gauges: Coolant temperature, fuel level, tachometer, hour meter	Power steering, hydrostatic
Audible system fault alarm	Ground line fuel fill with 160 liters capacity	ROPS cab with heater, defroster, pressurizer and cab recirculating fan
Backhoe, 4422 mm dig depth, side-shift, excavator-style backhoe,	Grouser style stabilizer shoes	Seat belt, retractable (50 mm)
Battery, maintenance free, 750 CCA	High ambient cooler package	Seat, air suspension with fabric seat cover
Boom, transport lock	Hydraulic oil cooler	Self canceling directional indicator
Brace, lift cylinder	Indicators: Air cleaner service, brake on, engine coolant, hydraulic oil level sight gauge	Spin-on fuel, engine, hydraulic and transmission oil filters
Brakes, Kevlar disc, oil immersed	Instrument panel lights	Starting system, thermal aid
Cat 3054C engine* (68.5 kW) or Cat C4.4 engine** (70 kW)	Intermittent front and rear wash/wipe	Stop and tail lights (2)
Coat hook	Key start/stop with auxiliary position	Swing transport lock
Electro-hydraulic slide frame lock	Left side doors with lock	Tires (2 front, 2 rear)
Engine enclosure	Lifting eye, backhoe (non-EU countries only)	Torque convertor
Fan, cooling and fan guard	Lights, working (4 front, 4 rear)	Throttles, hand and foot
Fast reversing shuttle, all gears	Load sensing, variable flow system with axial piston pump	Transmission, four-speed synchromesh
Flashing hazard, signal lights		Transmission neutralizer switch
Floor mat, rubber		Warning horn, front electric
		Water separator

Optional Equipment

Optional equipment may vary. Consult your Cat dealer for details.

Air conditioning	Fenders, front, All Wheel Drive	Mirror, exterior rearview, large
Alarm, back up	Guards	Powered Side Shift
Attachments, front loader	AWD driveshaft	Object handling installation, including lifting eye, boom and stick locks and audio-visual warning system
General purpose bucket 1.0 m ³	Teeth (GP/MP)	Operators station
Multi purpose bucket 1.03 m ³	Rear lights, roading	Canopy
1.03 m ³ with forks	Hydraulic valves, loader	Ride control
Attachments, backhoe buckets	3rd valve for GP/MP	Rotating beacon
Quick Coupler (Mechanical)	Hydraulic valves (auxiliary)	Stabilizer street pads
Automatic Transmission	Standard stick	Stick, extendable
Cat 3054C DIT* (74.5 kW) engine	Extendable stick	Tilt steering wheel
Cat C4.4** (74.5kW) engine	Hydraulic lines	Tool box, external
Counterweights	Hammer lines to stick	Transport locks
Bumper	Quick disconnects	Vandalism protection
Base	Lights	Visor cab
Stackables	Number plate, rear	
Cutting edge, bolt on	Roading	
Single piece		
Two piece		

* Standard for less regulated countries, meets stage II EU Emission Directive 97/68/EC.

** Standard for regulated countries, meets stage IIIA EU Emission Directive 2004/26/EC

Backhoe Loader E-Series

Complete product range.

	422E
Engine Power (Gross)	56.6 kW 77 HP
Control Type	Mechanical
Steer Mode	Two Wheel Steer
SAE Maximum dig depth (standard stick)	4.2 m
Loader Bucket Capacity	1.0 m ³
Loader Breakout Force	33 kN
Stick Tearout force	35 kN
Bucket Tearout force	63 kN
Hydraulic oil flow	125 l/min



	428E	432E	442E
Engine Power (Gross)	68.5 kW 93 HP	68.5 kW 93 HP	74.5kW 101 HP
Control Type	Mechanical	Pilot	Pilot
Steer Mode	Two Wheel Steer	Two Wheel Steer	Two Wheel Steer
SAE Maximum dig depth (standard stick)	4.2 m	4.4 m	4.6 m
Loader Bucket Capacity	1.0 m ³	1.0 m ³	1.0 m ³
Loader Breakout Force	55 kN	55 kN	55 kN
Stick Tearout force	35 kN	41 kN	46 kN
Bucket Tearout force	63 kN	63 kN	63 kN
Hydraulic oil flow	125 l/min	156 l/min	156 l/min



	434E Mechanical	434E Pilot	444E
Engine Power (Gross)	68.5 kW 93 HP	74.5 kW 101 HP	74.5 kW 101 HP
Control Type	Mechanical	Pilot	Pilot
Steer Mode	Equal Size Wheel	Equal Size Wheel	Equal Size Wheel
SAE Maximum dig depth (standard stick)	4.3 m	4.3 m	4.6 m
Loader Bucket Capacity	1.15 m ³	1.15 m ³	1.3 m ³
Loader Breakout Force	56 kN	56 kN	55 kN
Stick Tearout force	35 kN	41 kN	41 kN
Bucket Tearout force	63 kN	63 kN	63 kN
Hydraulic oil flow	125 l/min	156 l/min	156 l/min



432E Backhoe Loader

For more complete information on Cat products, dealer services, and industry solutions, visit us on the web at www.cat.com

© 2008 Caterpillar Inc.
All rights reserved

HEHB4294 (10-2009)

Materials and specifications are subject to change without notice. Featured machines may include additional equipment. See your Caterpillar dealer for available options.

CAT, CATERPILLAR, their respective logos, "Caterpillar Yellow" and the POWER EDGE trade dress, as well as corporate and product identity used herein, are trademarks of Caterpillar and may not be used without permission.

CATERPILLAR