

D8T

Track-Type Tractor



Engine

Engine Model	Cat® C15 ACERT	
Gross Power	259 kW	347 hp
Flywheel Power	231 kW	310 hp

Weights

Operating Weight	38 488 kg	84,850 lb
Shipping Weight	29 553 kg	65,152 lb

- **Operating Weight:** Includes hydraulic controls, blade tilt cylinder, coolant, lubricants, 100% fuel, ROPS, FOPS cab, SU-Blade, Single-Shank Ripper, 560 mm (22 in) MS shoes, and operator.
- **Shipping Weight:** Includes coolant, lubricants, 20% fuel, ROPS, FOPS cab, and 560 mm (22 in) MS shoes.

D8T Track-Type Tractor

Strength from the past. Power for the future.™ The D8T combines power and efficiency with advanced technology for outstanding production at a lower cost-per-yard.

C15 Engine with ACERT® Technology

- ✓ ACERT Technology works at the point of combustion to optimize engine performance and provide low exhaust emissions. Matched with the torque divider and power shift transmission, it provides years of dependable and efficient service. **pg. 4**

Operator Station

- ✓ Designed for operator comfort, convenience, and productivity. Machine control and vital information is provided at the operator's fingertips. A full day of work is no problem in this efficient work place. **pg. 6**

Implement and Steering Controls

- ✓ Electro-hydraulic implement controls allow low operator effort for dozing and ripping. Steering and gear selection in a one-hand control system enhances operator comfort. **pg. 8**

Work Tools

Various bulldozer blades, rippers, winches, and other options allow you to adapt the D8T to match your specific application, making you more productive. **pg. 12**

Serviceability and Customer Support

- ✓ Combining easy to access, modular components with your Caterpillar® Dealer's advanced rebuild and repair capabilities ensures rapid component replacement and minimum downtime. **pg. 13**

Engineered for demanding work.

The durable construction of the D8T is well suited for tough working conditions. Combined with the C15 engine for superior performance, fuel economy and meeting emission targets with the help of ACERT Technology, it keeps material moving with the reliability and low operating costs you expect from Cat tractors.



Drive Train

The electronically controlled power shift transmission, efficient differential steering and durable planetary final drives deliver outstanding power transfer and long life to ensure maximum productivity. **pg. 9**

Undercarriage

The proven elevated sprocket undercarriage isolates the drive train components from ground-induced impacts. The suspended undercarriage puts more track on the ground for higher traction and less track slip. It absorbs shocks for a smoother ride and longer machine life. **pg. 10**

Structure

- ✓ Mainframe is heavy, strong and durable. Full box sections, steel castings and continuous rolled rails provide durable support to the suspended undercarriage, elevated final drives and other integral frame components. **pg. 11**



✓ *New Feature*

C15 Engine with ACERT® Technology

A combination of innovations working at the point of combustion, ACERT Technology optimizes engine performance while meeting EPA Tier 3 and EU Stage IIIa engine exhaust emission regulations for off-road applications.



C15. Performing at full-rated net power of 231 kW (310 hp) at 1850 rpm, the large displacement and high torque rise allow the D8T to doze through tough material. Matched to the high-efficiency torque divider and electronically controlled power shift transmission, it will provide years of dependable service.

Constant Net Horsepower. Constant net horsepower allows the operator to maintain high standards of performance and response, even when parasitic loads, such as the on-demand cooling fan, are applied. The engine automatically adjusts to maintain power output and conversely lowers output when demands are low. This converts to a fuel savings in cooler climates.

C15 Block. The one-piece, grey iron block features generous ribbing for stiffness and heavy bearing bulkheads for rigidity and strength. Incorporation of straight o-ring connection points reduces the loss of engine oil and fluids.

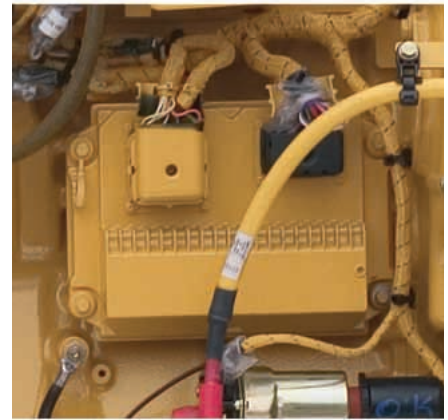

ADEM™ A4 Engine Controller.

The ADEM A4 electronic control module manages fuel delivery to get the best performance per gallon (liter) of fuel used. It provides flexible fuel mapping, allowing the engine to respond quickly to varying application needs. It tracks engine and machine conditions while keeping the engine operating at peak efficiency.

Fuel Delivery. Multiple injection fuel delivery involves a high degree of precision. Precisely shaping the combustion cycle lowers combustion chamber temperatures generating fewer emissions and optimizing fuel combustion; translating into more work output for your fuel cost.

MEUI Fuel System. A highly evolved fuel system with a proven record of reliability in the field. MEUI combines the technical advancement of an electronic control system with the simplicity of direct mechanically controlled unit fuel injection. The MEUI system excels in its ability to control injection pressure over the entire engine operating speed range. These features allow the C15 to have complete control over injection timing, duration, and pressure.

ATAAC and Airflow. Air-to-air aftercooling keeps air intake temperatures down and, in concert with the tight tolerance combustion chamber components, maximizes fuel efficiency and minimizes emissions. Significant improvements in air flow are generated by a water-cooled turbocharger, unique cross-flow head and single overhead cam.

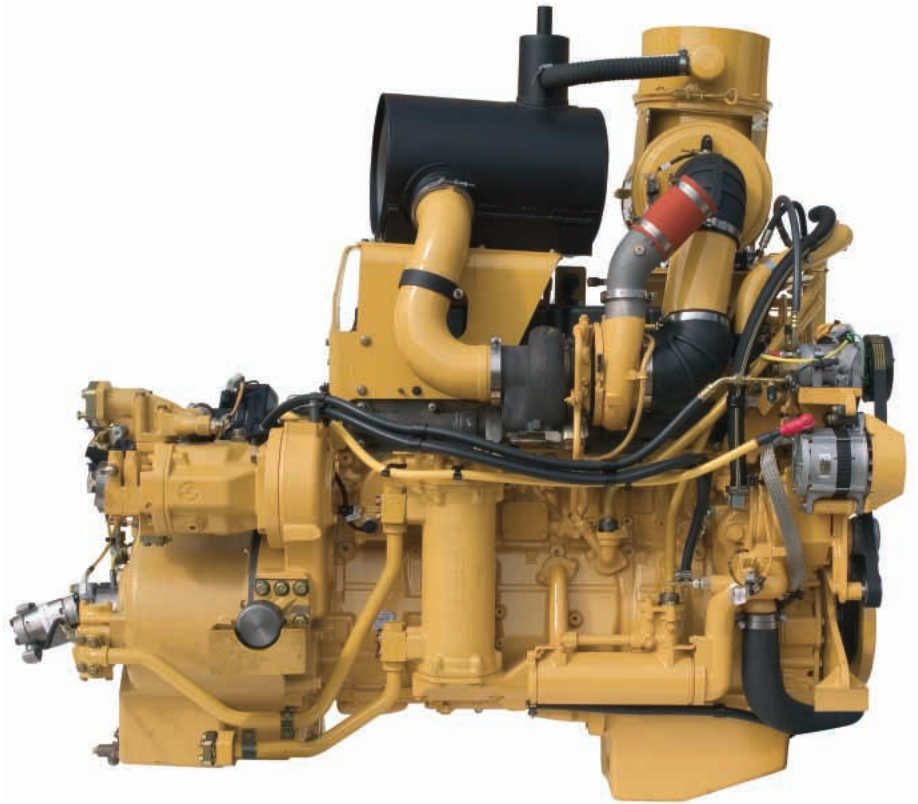

Turbocharging and Air-to-Air Aftercooling. Provides high horsepower with faster response time while keeping intake temperatures low for long hours of continuous operation.

Service. Easier maintenance and repair through monitoring key functions and logging critical indicators. Electronic diagnostic access is possible with a single tool, the Cat Electronic Technician.

Operator Station

Designed for operator comfort, convenience, and productivity, the state-of-the-art cab sets a new standard.



1) Steering Control. Dual-twist tiller control with standard differential steering controls direction and degree of turns, forward-reverse shifting, and gear selection in a single control handle—enhancing operator comfort.

2) Cat Comfort Series Seat.

Fully adjustable and designed for comfort and support. Thick seat and back cushions provide support for the lower back and thighs, while allowing unrestricted arm and leg movement. Wide retractable seat belt provides positive and comfortable restraint.

3) Adjustable Armrests. Standard adjustable armrests provide additional comfort for the operator.



4) Electronic Ripper Control. A rigidly mounted handgrip, with low effort thumb and finger controls, provides firm support and positive control of the ripper when operating in tough conditions. Programmable features, such as Auto Lift, Shank-Out and Auto Stow, increase efficiency for the operator.

5) Electronic, Programmable Dozer Control. Features such as blade response, blade float, auto blade pitch, and spread rate can be set and adjusted using the Advisor panel. Auto Blade Assist and AutoCarry options make the tractor even more efficient in specific applications.

6) Cat Monitoring Display System.

The combination dash mounted instrument cluster and the Advisor Monitoring System provide key machine operating information and give the operator and service technician insight into the machine's operation and maintenance needs.

In-Dash Instrument Cluster.

The instrument panel, with easy to read gauges and warning lamps, keeps the operator aware of any potential problems. All gauges and readouts are easily visible in direct sunlight.

Advisor Monitoring System (AMS).

On-board diagnostic abilities minimize downtime and maximize machine performance.

7) Wide Panoramic View. The operator station offers an exceptional viewing area. A large view hole in the single-shank ripper frame provides a view of the ripper tip. The tapered hood, notched fuel tank and narrow single-shank ripper carriage give the operator a clear line of sight to the front and rear work areas. The large single-pane door windows provide an excellent view to the sides and blade.

8) Heating and Air Conditioning.

Conveniently located air circulation vents evenly distribute airflow within the cab. Controls are easily accessible from the operator seat.



Fuse Panel and Diagnostic Access.

The new compartment features a single location fuse panel that includes a diagnostic port for the Cat ET to connect for rapid machine diagnostics.

Comfortable Operation. Standard isolation-mounted cab reduces noise and vibration. The cab is pre-wired for a 12-volt or 24-volt radio, equipped with two speakers, an antenna and a radio mount recessed in the headliner.

Implement and Steering Controls

Low effort control functions significantly reduce operator fatigue for increased performance.



Dozer Control Lever. A low-effort, electronic dozer control handle gives the operator control of all dozer functions with one hand. Fore/aft movement of the lever lowers and raises the blade. Left/right movement directionally tilts the blade. The thumb lever at the top of the handle controls blade pitch fore and aft. The trigger switch initiates the forward pitch during the spread and fill applications.

Automated Blade Assist (ABA). A semi-automatic dozer control function that increases efficiency while reducing operator workload by automating some of the more common blade functions. The ABA system for a dual-tilt tractor contains Auto Pitch.

Auto Pitch. Presetting blade pitch angles for optimal performance during the dozing cycle: one setting each for load, carry, spread and return. Auto Pitch is activated on the Advisor keypad; the operator can select the dozing segment by pushing the yellow button on the left side of the dozer handle.

AccuGrade® Ready Option (ARO).

The AccuGrade Ready Option (ARO) provides a factory installed on-board platform for the AccuGrade GPS installation. All of the changes required to the electrical system, hydraulic system, blade, and cab are incorporated into the ARO. Mounting brackets added on the blade allow easy installation of the masts. Console mounting in the cab secure the in-cab display. Plug-in points inside the cab and on the front of the machine make it easy to install electronic components.

Computer Aided Earthmoving System (CAES) (optional).

This on-board electronic site plan directs machine operators, in real-time, where to cut and fill. A graphical map of the design plan and a view of the machine's horizontal and vertical position simplify operation and enhance production. This advanced information tool combines GPS technology (centimeter-level) and in-cab computing capabilities for precise grade and slope control. It has proven to provide measurable impact on work quality and overall productivity.

AutoCarry (optional). AutoCarry provides automatic blade control (raise and lower only) during the carry segment of the dozing cycle. Drawbar pull, ground speed, track slippage, and machine attitude are integrated to control track slippage and maintain optimal blade loads. AutoCarry is intended to enhance the operator's productivity in high production earth moving with carry distances over 100 feet.



Ripper Control Lever. A rigidly mounted handgrip provides firm support for the operator even when ripping in the roughest terrain. The low effort thumb lever controls raising and lowering. The finger lever controls shank-in and shank-out positioning. The thumb button automatically raises the ripper.



Tiller Control System. A single lever, dual-control tiller controls machine speed, direction, and steering. The tiller allows the operator to work precisely in close areas, around structures, grade stakes, other machines and during fine grading work.

Drive Train

The drive train provides maximum efficiency in combination with the C15 engine with ACERT Technology.

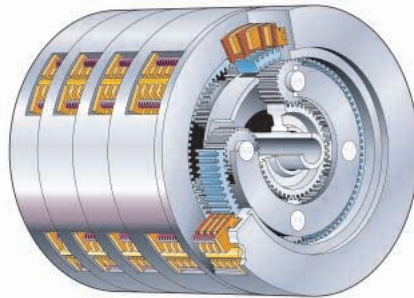

Torque Divider. A high efficiency torque divider with fixed stator provides high torque multiplication while shielding the drive train from sudden torque shocks and vibration.

Differential Steering System. A planetary differential turns the machine by speeding up one track and slowing the other, while maintaining full power to both. The system consists of:

- Three planetary gear sets:
 - Two planetary gear sets (steering and drive) make up the “dual differential,” which performs the traditional drive function (forward or reverse). Unlike competitive machines, the differential also performs a steering function with input from the steering motor.
 - A third planetary gear set, the “equalizing planetary,” resides inside the transmission case. It is connected to the dual differential, which provides a maximum speed difference between the right and left final drives during a turn.
- A dedicated variable-displacement hydraulic pump.
- A bi-directional, fixed-displacement steering motor.
- Heavy-duty steering drive gears.

Planetary Power Shift Transmission.

Three speeds forward and three speeds reverse, utilizing large diameter, high capacity, oil-cooled clutches.

- Modulation system permits fast speed and direction changes.
- Modular transmission and differential slide into rear case for servicing ease, even with ripper installed.
- Oil-to-water cooler for maximum cooling capacity.
- Forced oil flow lubricates and cools clutch packs to provide maximum clutch life.

Power Shift with Differential Steer

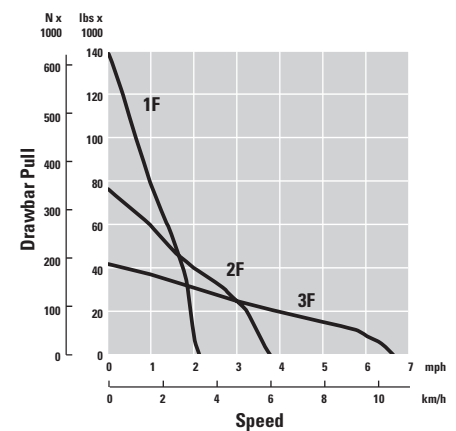

Drawbar Pull vs. Speed. As loads on the tractor increase, the D8T offers unmatched lugging capability and smooth shifting as the need occurs to change gears under varying loads. The 3-speed forward, 3-speed reverse transmission, backed by differential steering, offers excellent runout speeds and accurate steering capability under load.

Elevated Final Drives. Isolated from ground and equipment induced impact loads for extended power train life.

- Crown-shaved drive gears provide smooth, quiet, low maintenance operation.
- Splash lubrication and Duo-Cone® Seals extend service life.

Undercarriage

The Caterpillar elevated sprocket undercarriage is designed for optimized machine balance and best possible performance and component life.



Suspended Undercarriage Design.

Suspended undercarriage design absorbs impact loads to reduce the shock loads transferred to the undercarriage by up to 50 percent in uneven terrain.

Bogie Suspension. Bogie suspension conforms closely to the ground providing up to 15 percent more ground contact, especially in hard, uneven terrain. Higher traction means less slippage, better balance, and a smoother ride.



Integrated Carrier Roller Mount.

The carrier roller mount is cast into the track roller frame making it easier to add the optional carrier roller in the field, if conditions require it.

Rollers and Idlers. Feature symmetric Duo-Cone seals for long sealing life to prevent oil loss and dirt entry. Toric rings maintain performance over a wide range of temperatures. Rollers and idlers are serviceable and rebuildable to provide value. Abutment-style caps securely attach rollers and idlers to the bogies.

Roller Frames. Roller frames are tubular to resist bending and twisting, with added reinforcement where operating loads are highest.

- Roller frames attach to tractor by a pivot shaft and pinned equalizer bar.
- Large pivot shaft bushings operate in an oil reservoir.
- A low friction, no maintenance bushing is used in the saddle connection.
- Aligned to use more of the available wear material, running the track to the outside of the rollers in forward and to the inside in reverse.

Sprocket Segments. Made exclusively of Caterpillar Tough Steel™ for longer wear life and precision machined after heat treat for proper fit. Segments can be removed or replaced without breaking the track.

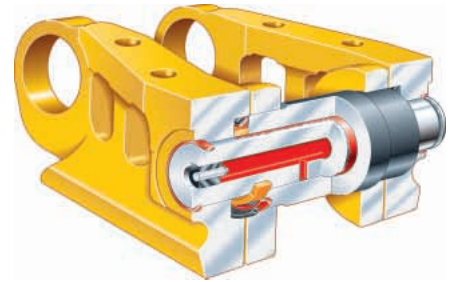

Positive Pin Retention (PPR) Sealed and Lubricated Track. Designed for high-impact and high load applications. The PPR exclusive Caterpillar design locks the link to the pin.

Track Shoes. Track shoes come in a variety of sizes and styles to best match the working conditions.

Structure

Engineered to provide durability and the solid support necessary for maximum production and service life in the most demanding work.



Tag-Link. The Tag-Link brings the blade closer to the machine for more precise dozing and load control.

The Tag-Link design provides solid lateral stability and better cylinder positions for constant break out force, independent of blade height.

Mainframe Strength. The D8T mainframe is built to absorb high impact shock loads and twisting forces.

Frame Rails. Full box section, designed to keep components rigidly aligned.

Heavy Steel Castings. Adds strength to the main case, equalizer bar saddle, front cross member and tag-link trunnion.

Top and Bottom Rails. Continuous rolled sections, with no machining or welding, to provide superior mainframe durability.

Main Case. Elevates the final drives well above the ground level work area to protect them from impact loads, abrasion and contaminants.

Pivot Shaft. The D8T pivot shaft runs through the mainframe and connects to the roller frames, allowing independent oscillation. The full-length pivot shaft distributes impact loads throughout the case, reducing the bending stress on the case.

Equalizer Bar. The equalizer bar features limited slip seals and an oil-lubricated joint for better oil flow. Large forged pads reduce wear on the mainframe and extend sealed joint life.

Work Tools

Work Tools and Ground Engaging Tools (G.E.T.) provide the flexibility to match the machine to the job, maximizing performance.



Bulldozers. All blades feature a strong box-section design that resists twisting and cracking. Blades are made of Cat DH-2™ steel that has high tensile strength and stands up to the most severe applications. Heavy moldboard construction and hardened bolt-on cutting edges and end bits add strength and durability.

• **Semi-Universal Blade.** The Semi-Universal blade is built for tough applications where penetration is more important than capacity. The “SU” blade is more aggressive in penetrating and loading material than the “U” blade. The blade wings are designed for superior load retention and penetration in tightly packed materials and for finishing applications. Can also be configured with a push plate for push loading scrapers.

• **High-Capacity Universal Blade.**

The high-capacity Universal blade offers maximum capacity and is perfect for moving big loads over long distances. The “U” blade has large blade wings and is ideal for stockpile work, reclamation, charging hoppers or trapping for loaders.

Optional Dual Tilt. Improves load control and allows the operator to optimize the blade pitch angle for each portion of the dozing cycle.

Single Lever. Controls all blade movements, including the optional dual tilt.

Cutting Edges and End Bits. Cutting edges are DH-2 steel. End bits are DH-3™ steel to provide maximum service life in tough materials.

Rippers. Single and multi-shank rippers are made to penetrate tough material fast and rip thoroughly for use in a variety of materials.



Single-Shank Ripper. Operator can adjust the shank depth from the seat using an optional single shank pin puller. Large upper frame view hole improves ripper tip visibility. Heat-treated spacer bars in the ripper carriage extend pocket life and reduce shank notching. Large one-piece shank is available in deep rip configuration.



Multi-Shank Ripper. Tailors the tractor to the material by using one, two or three shanks.

Hydraulics. The D8T features field-proven load-sensing hydraulics which respond to operating requirements by automatically and continually adjusting attachment hydraulic power, increasing both operator and machine efficiency.

Rear Counterweights. Provide proper tractor balance to maximize dozing production. Recommended if not equipped with any other rear attachment.

Winches. Several options are available. Contact your Caterpillar Dealer.

Serviceability and Customer Support

The most serviceable machines from the most committed dealers. World-class product support. The Cat Dealer network trained experts keep your fleet up and running, maximizing your equipment investments. Caterpillar. The difference counts.™

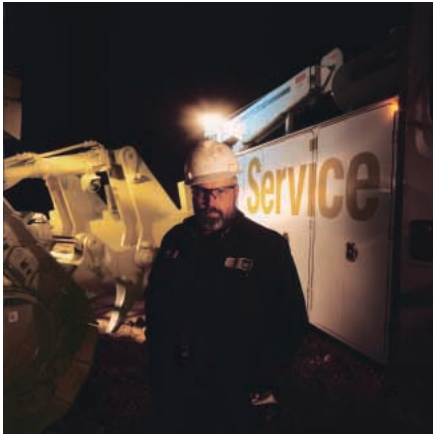

Serviceability. Minimizes maintenance and repair downtime. New sight gauges, filter locations, improved access to oil and coolant sampling ports, and an engine compartment mounted work lamp, make daily and periodic service faster and easier. Equipped with a dozer and ripper, there are only 18 lube points.

Engine Oil Filter. Engine oil filter is located on the engine for easy servicing access and minimal downtime. Save further time with the optional quick oil change attachments.

Water Separator and Fuel Filter. Easily located just inside the engine access panel, the water separator functions as the primary fuel filter, just ahead of the secondary fuel filter.

Quick Disconnect Fittings. Allow for fast diagnosis of the power train, hydraulics and attachment oil systems.

S•O•SSM Analysis. Scheduled Oil Sampling made easier through live sampling ports for the engine oil, hydraulics and coolant.



Caterpillar Product Link PL300 (optional).

This option allows the customer or dealer to obtain machine diagnostics and location information from their offices. Product Link PL300 provides updates on service meter hours, machine condition and machine location, as well as integrated mapping/route planning. Built-in flexibility allows for future technology development.

Machine Selection. Make detailed comparisons of the machines you are considering before you buy. How long do components last? What is the cost of preventive maintenance? What is the true cost of lost production? Your Cat Dealer can give you answers to these very important questions.

Purchase. Consider the financing options available, as well as day-to-day operating costs. This is also the time to look at dealer services that can be included in the cost of the machine to yield lower equipment owning and operating costs over the long run.

Product Support. Plan for effective maintenance before buying equipment. Choose from your dealer's wide range of maintenance services at the time you purchase your machine. Programs such as Custom Track Service (CTS), S•O•S analysis, Technical Analysis and guaranteed maintenance contracts give peak life and performance to your machine.



Parts Program. You will find nearly all parts at your dealer parts counter. Cat Dealers use a worldwide computer network to find in-stock parts to minimize machine downtime.

Ask about your Cat Dealer's exchange program for major components. This can shorten repair time and lower costs.

Remanufactured Components. Genuine Cat Remanufactured parts save you money. You receive the same warranty and reliability as new products at cost savings of 40 to 70 percent. Components available for the drive train, engine, and hydraulics.

Engine

Engine Model	Cat C15 ACERT	
Gross Power	259 kW	347 hp
Flywheel Power	231 kW	310 hp
Net Power – Caterpillar	231 kW	310 hp
Net Power – ISO 9249	231 kW	310 hp
Net Power – SAE J1349	229 kW	307 hp
Net Power – EU 80/1269	231 kW	310 hp
Net Power – DIN 70020	322 PS	
Bore	137 mm	5.4 in
Stroke	172 mm	6.75 in
Displacement	15.2 L	928 in ³

- Engine ratings apply at 1850 rpm.
- Net power advertised is the power available at the flywheel when the engine is equipped with fan, air cleaner, muffler, and alternator.
- No derating required up to 3658 m (12,000 ft) altitude, beyond 3658 m (12,000 ft) automatic derating occurs.

Service Refill Capacities

Fuel Tank	643 L	170 gal
Cooling System	77 L	20.3 gal
Engine Crankcase*	38 L	10 gal
Power Train	155 L	41 gal
Final Drives (each)	12.5 L	3.3 gal
Roller Frames (each)	65 L	17.2 gal
Pivot Shaft Compartment	40 L	10.6 gal
Hydraulic Tank	75 L	19.8 gal
Variable Fan Hub	3.1 L	0.82 gal

* With oil filters.

Weights

Operating Weight	38 488 kg	84,850 lb
Shipping Weight	29 553 kg	65,152 lb

- Operating Weight: Includes hydraulic controls, blade tilt cylinder, coolant, lubricants, 100% fuel, ROPS, FOPS cab, SU-Blade, Single-Shank Ripper, 560 mm (22 in) MS shoes, and operator.
- Shipping Weight: Includes coolant, lubricants, 20% fuel, ROPS, FOPS cab, and 560 mm (22 in) MS shoes.

Undercarriage

Shoe Type	Moderate Service	
Width of Shoe	560 mm	22 in
Shoes/Side	44	
Grouser Height	78 mm	3 in
Pitch	216 mm	8.5 in
Ground Clearance	618 mm	24.3 in
Track Gauge	2082 mm	82 in
Length of Track on Ground	3207 mm	10.5 ft
Ground Contact Area	3.58 m ²	5,554 in ²
Track Rollers/Side	8	
Number of Carrier Rollers	1 per side (optional)	

- Positive Pin Retention Track.

Hydraulic Controls

Pump Type	Piston-type, Variable displacement	
Pump Output (Steering)	276 L/min	73 gal/min
Pump Output (Implement)	226 L/min	60 gal/min
Tilt Cylinder Rod End Flow	130 L/min	34 gal/min
Tilt Cylinder Head End Flow	170 L/min	45 gal/min
Bulldozer Relief Valve Setting	24 100 kPa	3,500 psi
Tilt Cylinder Relief Valve Setting	24 100 kPa	3,500 psi
Ripper (Lift) Relief Valve Setting	24 100 kPa	3,500 psi
Ripper (Pitch) Relief Valve Setting	24 100 kPa	3,500 psi
Steering	39 200 kPa	5,700 psi

- Steering Pump output measured at 2300 rpm and 30 000 kPa (4351 psi).
- Implement Pump output measured at 1850 rpm and 6895 kPa (1000 psi).
- Electro-hydraulic pilot valve assists operations of ripper and dozer controls. Standard hydraulic systems includes four valves.
- Complete system consists of pump, tank with filter, oil cooler, valves, lines, linkage and control levers.

Transmission

1 Forward	3.4 kph	2.1 mph
2 Forward	6.1 kph	3.8 mph
3 Forward	10.6 kph	6.6 mph
1 Reverse	4.5 kph	2.8 mph
2 Reverse	8 kph	5 mph
3 Reverse	14.2 kph	8.8 mph
1 Forward – Drawbar Pull (1000)	618.5 N	139 lbf
2 Forward – Drawbar Pull (1000)	338.2 N	76 lbf
3 Forward – Drawbar Pull (1000)	186.9 N	42 lbf

Blades

Type	8SU	
Capacity (SAE J1265)	8.7 m ³	11.4 yd ³
Width (over end bits)	3940 mm	12.9 ft
Height	1690 mm	5.5 ft
Digging Depth	575 mm	22.6 in
Ground Clearance	1225 mm	48.2 in
Maximum Tilt	883 mm	34.8 in
Weight* (without hydraulic controls)	4789 kg	10,557 lb
Total Operating Weight** (with Blade and Single-Shank Ripper)	38 488 kg	84,850 lb
Type	8U	
Capacity (SAE J1265)	11.7 m ³	15.3 yd ³
Width (over end bits)	4267 mm	14 ft
Height	1740 mm	5.71 ft
Digging Depth	575 mm	22.6 in
Ground Clearance	1225 mm	48.2 in
Maximum Tilt	954 mm	37.5 in
Weight* (without hydraulic controls)	5352 kg	11,800 lb
Total Operating Weight** (with Blade and Single-Shank Ripper)	39 051 kg	86,093 lb
Type	8A	
Capacity (SAE J1265)	4.7 m ³	6.1 yd ³
Width (over end bits)	4990 mm	16.3 ft
Height	1174 mm	3.85 ft
Digging Depth	628 mm	24.7 in
Ground Clearance	1308 mm	51.5 in
Maximum Tilt	729 mm	28.7 in
Weight* (without hydraulic controls)	5459 kg	12,035 lb
Total Operating Weight** (with Blade and Single-Shank Ripper)	39 158 kg	86,328 lb

* Includes blade tilt cylinder.

**Operating Weight: Includes hydraulic controls, blade tilt cylinder, coolant, lubricants, 100% fuel, ROPS, FOPS cab, Blade, Single-Shank Ripper, 560 mm (22 in) MS shoes, and operator.

Rippers

Type	Single-Shank, Adjustable Parallelogram	
Number of Pockets	1	
Maximum Clearance Raised (under tip, pinned in bottom hole)	636 mm	25 in
Maximum Penetration (standard tip)	1130 mm	44.4 in
Maximum Penetration Force (shank vertical)	127.3 kN	28,620 lb
Pry out Force	222.7 kN	50,070 lb
Weight (without hydraulic controls)	4085 kg	9,005 lb
Total Operating Weight* (with SU-Blade and Ripper)	38 488 kg	84,850 lb
Type	Multi-Shank, Adjustable Parallelogram	
Number of Pockets	3	
Overall Beam Width	2464 mm	97 in
Maximum Clearance Raised (under tip, pinned in bottom hole)	593 mm	23.35 in
Maximum Penetration (standard tip)	780 mm	30.7 in
Maximum Penetration Force (shank vertical)	124.2 kN	27,920 lb
Pry out Force (Multi-Shank Ripper with one tooth)	227.9 kN	51,230 lb
Weight (one shank, without hydraulic controls)	4877 kg	10,752 lb
Additional Shank	332 kg	732 lb
Total Operating Weight* (with SU-Blade and Ripper)	39 280 kg	86,597 lb

* Total Operating Weight: Includes hydraulic controls, blade tilt cylinder, coolant, lubricants, 100% fuel, ROPS, FOPS cab, Blade, Ripper, 560 mm (22 in) MS shoes, and operator.

Winches

Winch Model	PA140VS	
Weight*	1790 kg	3,947 lb
Oil Capacity	15 L	4 gal
Increased Tractor Length	563 mm	22.2 in
Winch Length	1430 mm	56.3 in
Winch Case Width	1160 mm	45.6 in
Drum Width	320 mm	12.6 in
Flange Diameter	457 mm	18 in
Recommended Cable size	29 mm	1.13 in
Optional Cable size	32 mm	1.25 in
Drum Capacity – Recommended Cable	84 m	276 ft
Drum Capacity – Optional Cable	59 m	193 ft
Cable Ferrule Sizes – Outside Diameter	60 mm	2.36 in
Cable Ferrule Sizes – Length	70 mm	2.76 in

- Variable speed, hydraulically driven, dual braking system, three roller fairlead.

* Weight: Includes pump and operator controls.

Standards

- ROPS (Rollover Protective Structure) offered by Caterpillar for the machine meets ROPS criteria SAE J1040 MAY94, ISO 3471:1994.
- FOPS (Falling Object Protective Structure) meets SAE J/ISO 3449 APR98 Level II, and ISO 3449:1992 Level II.

Dimensions

All dimensions are approximate.

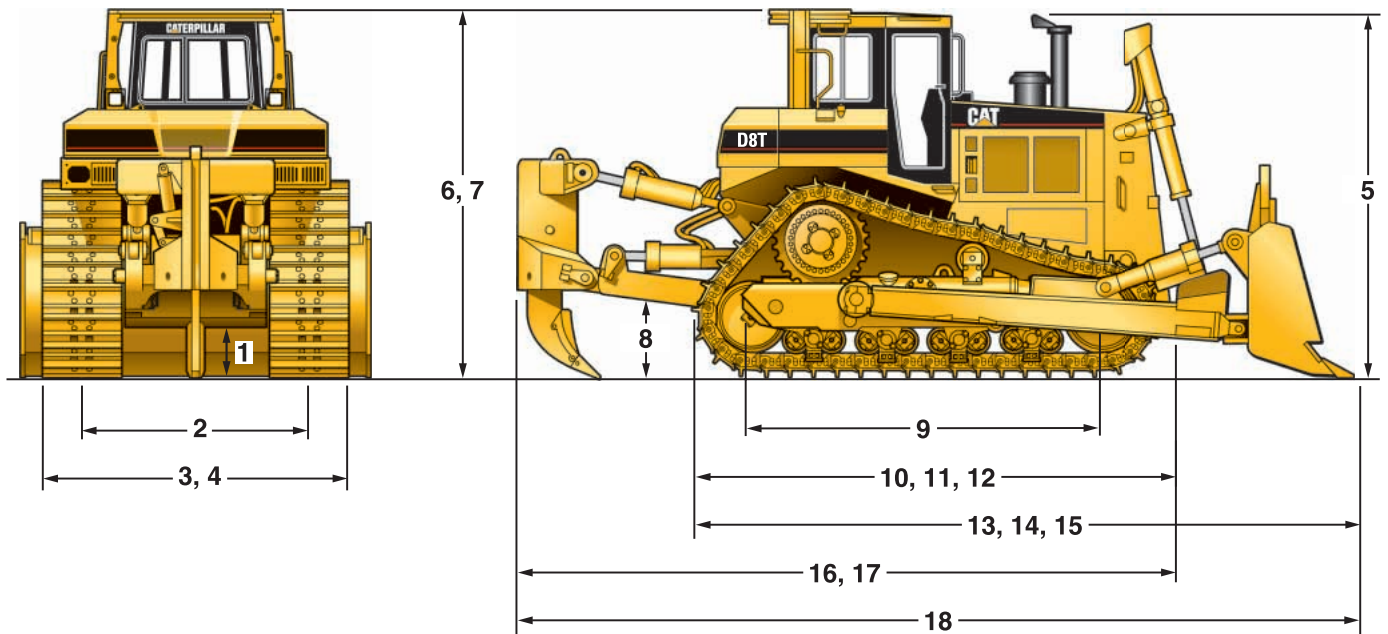

1	Ground Clearance	618 mm	24.3 in
2	Track Gauge	2.08 m	82 in
3	Width without Trunnions (Standard Shoe)	2642 mm	8.7 ft
4	Width Over Trunnions	3057 mm	10 ft
5	Height (Top of Stack)	3448 mm	11.3 ft
6	Height (FOPS Cab)	3456 mm	11.34 ft
7	Height (ROPS/Canopy)	3461 mm	11.35 ft
8	Drawbar Height (Center of Clevis)	708 mm	27.87 in
9	Length of Track on Ground	3207 mm	126.26 in
10	Overall Length Basic Tractor	4641 mm	15.2 ft

11	Length Basic Tractor with Drawbar	4998 mm	16.4 ft
12	Length Basic Tractor with Winch	5275 mm	17.3 ft
13	Length with SU-blade	6091 mm	20 ft
14	Length with U-blade	6434 mm	21.1 ft
15	Length with A-blade	6278 mm	20.6 ft
16	Length with Single-Shank Ripper	6422 mm	21 ft
17	Length with Multi-Shank Ripper	6344 mm	20.8 ft
18	Overall Length (SU-Blade/SS Ripper)	7872 mm	25.8 ft

Standard Equipment

Standard equipment may vary. Consult your Caterpillar dealer for details.

ELECTRICAL

- Alternator, 100-amp brushless
- Back-up Alarm
- Batteries (4) maintenance free 12-volt, 24-volt system
- Converter, 12-volt, 10-amp, two power outlets
- Diagnostic connector
- Horn, forward warning
- Starting receptacle

OPERATOR ENVIRONMENT

- Advisor operator interface:
 - Electronic monitoring system
 - Diagnostic service information
 - Operator preferences
- Armrests, adjustable
- Cab, ROPS, FOPS, sound suppressed
- Controls, electronic implement with lockout
- Decelerator pedal
- Dual-twist tiller control
- Engine speed control, electronic
- Heater
- Hydraulic system, electronically controlled
 - for bulldozer and ripper control
- Mirror, rearview
- Radio-ready cab
- Seat, adjustable contour suspension
 - (gray fabric)
- Seatbelt, retractable 76 mm (3 in)
- Steering control, twist tiller with touch shift
- Wipers, intermittent

UNDERCARRIAGE

- 560 mm (22 in) moderate service grouser
 - with sealed and lubricated track (44 section)
- Rollers and idlers, lifetime lubricated
- Sprocket rim segments, replaceable
- Suspension-type undercarriage,
 - Eight-roller tubular track roller frame
 - Carrier roller ready
- Track adjusters, hydraulic
- Track guides
- Two-piece master link

POWER TRAIN

- C15 with ACERT Technology
 - 24-volt electric start
- Advanced Modular Cooling System (AMOCS)
- Aftercooler, air-to-air (ATAAC)
- Air filter with electronic service indicator
- Auto-kickdown (auto downshift)
- Automatic shift
 - (2F/2R, 2F/1R, 1F/2R)
- Coolant, extended life
- Directional shift management
- Ether starting aid, automatic
- Fan, suction with hydraulic demand drive
- Four planet, double-reduction planetary final drives
- Fuel priming pump, electric
- Muffler with rain cap
- Parking brake, electronic
- Pre-cleaner with dust ejector
- Prescreener
- Separator, water/fuel
- Thermal shields
- Torque divider
- Transmission, electronic control, (3F/3R speeds)
- Turbocharger, wastegate
- Water separator

OTHER STANDARD EQUIPMENT

- Air conditioner box, corrosive resistant
- Auto-blade assist and AutoCarry ready
- CD ROM Parts Book
- Ecology drains: engine oil, coolant,
 - hydraulic oil, torque converter, fuel tank,
 - power train case and transmission
- Engine enclosures and hood, perforated
- Equalizer bar, pinned
- Front pull device
- Guards:
 - Bottom, hinged
 - Radiator, hinged fan blast deflector
- Independent steering and attachment
 - hydraulic pumps
- Oil cooler, hydraulic
- Product Link ready
- S•O•SSM sampling ports
- Toolbox
- Under-hood standard service lamp
- Vandalism protection (8 caplocks)

Optional Equipment

Optional equipment may vary. Consult your Caterpillar dealer for details.

ELECTRICAL

- Alternator, 150-amp
- Converter, 24 volt to 12 volt
- Light, ripper
- Lights, supplemental:
 - 6 Halogen
 - 6 HID
 - 8 HID high-mount for waste application
 - 10 Halogen
 - 10 Halogen high-mount for waste application
 - 10 Halogen, sweeps
- Warning, strobe
- Switch, disconnect, remote mounted

GUARDS

- Fan, debris
- Final drive and seals
- Fuel tank
- Idler seals
- Pivot shaft seal
- Radiator, heavy-duty, hinged
- Rear tractor
- Screen, rear
- Sweeps
- Track roller
- Transmission
- Undercarriage

UNDERCARRIAGE

- Non-suspended
- Tracks, Pair, Sealed and Lubricated (Standard arrangement):
 - 560 mm (22 in), Extreme service
 - 560 mm (22 in), Extreme service PPR
 - 610 mm (24 in), Extreme service
 - 660 mm (26 in), Moderate service
 - 710 mm (28 in), Moderate service
- Tracks, Pair, Sealed and Lubricated (LGP arrangement):
 - 810 mm (32 in), Moderate service
 - 965 mm (38 in), Extreme service
- Roller options:
 - Carrier rollers (one per side)
- Seals, symmetrical, idler/roller

POWER TRAIN

- Fan, reversible
- Fuel system, fast fill
- Pre-cleaner, turbine
- Prelube, engine, automatic
- Quick oil change system
- Radiator, high ambient

OPERATOR ENVIRONMENT

- Air conditioner
- Air conditioner, fender mounted
- Air conditioner, ROPS mounted
- Canopy
- Enhanced cab
- Glass, Ultra-strength up to 40 psi
- Operators Arrangement
 - (gives additional comfort for smaller operators)
- Seat, air suspension
- Seat, vinyl

SPECIAL ARRANGEMENTS

Hydraulic implement towing arrangement, Low Ground Pressure arrangement, Waste Handling arrangement and Woodchip arrangement, in addition to other optional attachments are available from the factory. Contact your Dealer for availability.

BULLDOZER ATTACHMENTS

- AccuGrade GPS attachment ready installation
 - (provides hydraulics, electrical, and blade mount for system)
- AutoCarry system
- Dual tilt cylinders
- 8SU Blade, with rock guard and wear plate
- 8SU Blade, with push plate
- 8U Blade, with rock guard
- Trunnion cover, (replaces trunnions)

RIPPERS

- Single-Shank* – Standard depth
- Single-shank* – Deep ripping
- Multi-Shank* (includes one tooth)
- Ripper attachments:
 - Additional tooth (for multi-shank ripper)
 - Pin Puller, hydraulic

OTHER ATTACHMENTS

- Counterweights*:
 - Front mounted
 - Rear mounted
- Drawbar, rigid
- Parts book, paper
- Starting aids:
 - Batteries, heavy-duty
 - Heater, engine coolant, 120- or 240-volt
- Striker bars, front and rear
- Winch*

* A rear attachment and/or counterweight is recommended for improved performance and balance.

D8T Track-Type Tractor

For more complete information on Cat products, dealer services,
and industry solutions, visit us on the web at www.cat.com

© 2004 Caterpillar
All Rights Reserved
Printed in U.S.A.

Materials and specifications are subject to change without notice.
Featured machines in photos may include additional equipment.
See your Caterpillar dealer for available options.

AEHQ5590 (9-04)

CATERPILLAR[®]