

# 740 EJECTOR

Articulated Truck



Cat® C15 Diesel Engine with ACERT® Technology

Net Power (ISO 9249) at 1700 rpm 327 kW/445 hp

Rated Payload 38 000 kg

Body Capacity

Heaped SAE 2:1 23.1 m<sup>3</sup>

# 740 Ejector Articulated Truck

*The 740 Ejector Caterpillar® Articulated Truck is a world-leading earthmoving solution.*

---

## Cat C15 Engine with ACERT Technology

- ✓ The core concept behind ACERT technology is advanced combustion. ACERT engine technology carefully controls the combustion process to reduce pollutant levels while maintaining performance and efficiency. **pg. 4**

---

## Performance and Productivity – Power Train

- ✓ The Cat C15 ACERT engine, matched with the seven-speed forward and two-speed reverse electronic controlled transmission, provides a wide operating range for smooth shifting. **pg. 5**

---

## Performance and Productivity – Suspension and Traction Control

Three-point front suspension provides a smooth ride, allowing the operator to travel at speed over rough terrain. Cross-axle differential locking system provides full driveline locking for maximum performance in adverse conditions. **pg. 6**

---

## Serviceability

Long service intervals and easy maintenance provide better machine availability, resulting in lower owning and operating costs. **pg. 10**

---

## Performance and Productivity – Ejector

The truck body features on-the-go ejecting capability and a self-cleaning ejector design, which offers clean load ejection and overcomes carry-back of sticky materials. **pg. 7**

*The 740 Ejector offers proven reliability and durability, high performance, low fuel consumption, operator comfort and low operating costs.*

✓ *New Feature*



---

### Durability and Reliability

The 740 Ejector has built-in durability and reliability. Cat purpose-built, articulated truck drivetrain components, front frame and hitch ensure maximum performance in the toughest applications. **pg. 11**

---

### Ease of Operation

Ergonomically designed wrap-around dash, tilt and telescopic steering wheel, easy-to-reach controls and outstanding all-around viewing promote fast, confident machine operation. **pg. 8**

---

### Operator Comfort

Large center-mounted cab, oscillating front axle, air suspension seat, full-size trainer seat and large storage space provide exceptional operator comfort. **pg. 9**

---

### Complete Customer Support

Your Cat dealer offers a wide range of services that can be set up under a customer support agreement when you purchase your equipment. The dealer will help you choose a plan that can cover everything from machine configuration to eventual replacement.



## Cat C15 Engine with ACERT Technology

*A combination of proven systems and innovative new technologies, ACERT engines optimize performance while meeting EU Stage IIIA engine exhaust emission regulations.*



**ACERT Technology.** The C15 ACERT engine introduces a series of evolutionary, incremental improvements that provide breakthrough engine technology built on systems and components developed by Caterpillar with proven reliability. The technology capitalizes on Caterpillar expertise in four core engine systems: fuel, air, electronics and after treatment. ACERT technology is a unique and revolutionary systems solution that enables Cat engines to meet today's clean air regulations, thus establishing the building blocks for attaining tomorrow's more stringent standards.

**C15 Block.** The one-piece, gray iron block features generous ribbing for stiffness and heavy bearing bulkheads for rigidity and strength as the crankshaft turns. Straight O-ring connection points reduce the loss of engine oil and fluids.

### **Cylinder Head and Piston Technology.**

The C15 has a cross-flow cylinder head with refined port geometry, which improves breathing and provides better combustion. The Monotherm/steel pistons have a forged steel design, which offers high strength, light weight and tighter tolerances. The result is better oil control, minimal blow-by and long liner life.

### **Advanced Diesel Engine Management (ADEM) A4 Engine Controller.**

The ADEM A4 electronic control module manages fuel delivery to get the best performance per liter or gallon of fuel used. The engine management system provides flexible fuel mapping, allowing the engine to respond quickly to varying application needs. It tracks engine and machine conditions while keeping the engine operating at peak efficiency.

**Fuel Delivery.** Multiple injection fuel delivery involves a high degree of precision. Precisely shaping the combustion cycle lowers combustion chamber temperatures, generating fewer emissions and optimizing fuel combustion. This translates into more work output for your fuel cost.

### **Noise Reduction Technologies.**

Noise reduction has been achieved through design changes to the isolated top cover, oil pan, multiple injection strategy, insulated timing case cover, sculpted crankcase and gear train refinements.

## Performance and Productivity – Power Train

*Integrated power train with more power, greater performance and lower fuel consumption – the power to do more work.*

**Mechanically Actuated Electronic Unit Injection (MEUI).** A highly evolved fuel system with a proven record of reliability in the field. It combines the technical advancement of an electronic control system with the simplicity of direct mechanically controlled unit fuel injection. It excels in its ability to control injection pressure over the entire engine operating speed range. These features allow the Cat C15 to have complete control over injection timing, duration, and pressure.

**Air-to-Air Aftercooling (ATAAC).** ATAAC keeps air intake temperatures down and, in concert with the tight tolerance combustion chamber components, maximizes fuel efficiency and minimizes emissions. Significant improvements in airflow are generated by a turbocharger, unique cross-flow head and single overhead cam.

**Wastegate Turbocharging.** Single wastegate turbocharger provides higher boost over a wide range, outstanding low-end performance with improved peak torque and enhanced engine response.

**Electronic Transmission.** The Caterpillar seven-speed electronically controlled transmission is designed specifically for the articulated truck and its applications. It features anti-hunt shift strategy for speed continuity. It also incorporates Individual Clutch Modulation (ICM) to ensure constant shift times even when the oil is cold.

**Two Reverse Gears.** The transmission arrangement provides a second reverse gear for improved performance when operating in longer rear hauling applications. First gear reverse is now of a lower ratio for increased rimpull on wet or steep grades.



**Controlled Throttle Shifting (CTS).** Significantly reduces power train stress and clutch wear by controlling engine speed, torque converter lock up and transmission clutch engagements.

**Engine Overspeed Inhibitor.** Electronic Transmission Control (ETC) protects against engine overspeeding by shifting the transmission up one gear at specified rpm settings. If the transmission is in its highest gear, torque converter lockup disengages.

**Caterpillar Engine Compression Brake.** Provides extra braking effort on downhill grades. It is an excellent match for the Cat C15 ACERT engine, turning it into a power absorbing air compressor. It has very fast response time and produces no additional heat, so it can be used continuously.

**Usable Rimpull.** Power train components work together to offer more usable rimpull at higher speeds on effective grades. In first gear, the torque converter overcomes grade resistance by sending more torque to the wheels and preventing engine lugging. On downhill grades, the engine compression brake works like a brake by slowing the machine.

**Hydraulic Fan.** The remote-mounted hydraulic fan is temperature sensitive providing variable speeds when needed, which minimizes power requirements. The result is more power to the ground and faster cycle time.

## Performance and Productivity – Suspension and Traction Control

*Suspension systems and traction control – delivering power to the ground in all conditions.*

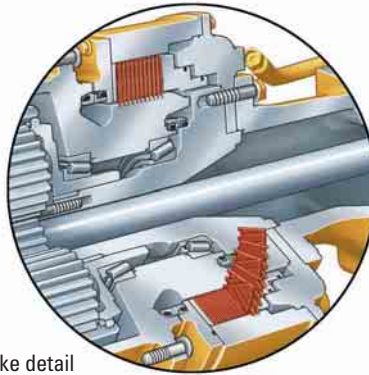
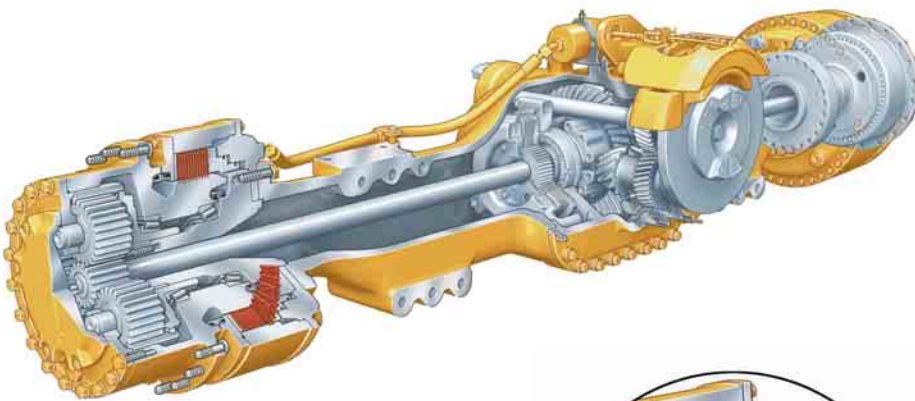

Service brake detail

**Front Suspension.** The three-point front suspension oscillates  $\pm 6^\circ$  to provide a smooth ride, allowing the operator to travel at speed over rough terrain and softening impact loads on structures and components.

### **Front Suspension Cylinders.**

Cylinders are designed for tough applications and offer a soft, smooth ride.

**Mounting Points.** Suspension mounting points are integrated into the axle housing, increasing reliability.

**Three-Point Suspension.** The front suspension uses an oscillating A-Frame with a lateral tie rod to control axle sideways movement.

**Rear Suspension.** Features a walking beam geometry that provides a stable ride for excellent load retention.

**Traction Control.** The traction control system is comprised of a wet clutched inter-axle differential and wet clutched cross-axle differentials. All differentials can be engaged and disengaged on-the-go for maximum versatility. When used together, the differentials provide 100 percent driveline locking.

**Inter-Axle Differential Lock.** Locks all three axles in unison and modifies torque distribution for excellent traction in poor underfoot conditions and on grades. It is operated by a switch located at the footrest.

**Cross-Axle Differential Locks.** Provides full driveline locking – all three axles and all six wheels – for maximum performance in the most adverse conditions. Acts in unison with the inter-axle differential lock when the footswitch is actuated and the dash-mounted switch is selected.

**Fast Hoist Cycle Times.** Fast body raise and lower times mean less time spent in the dump area.

**Enclosed, Oil-Cooled Brakes.** Multi-plate oil-immersed brakes are fitted to both front and center axles. These brakes provide outstanding stopping capability, while maintaining maximum durability and low wear characteristics.

**Steering System.** Cat articulated trucks use a load-sensing steering system for smooth, precise control. It features a single, variable displacement pump. Two double-acting, cushioned steer cylinders allow the machine to articulate  $45^\circ$  to the left or right, permitting precise positioning in tight areas. Its compact Hand Metering Unit controls the cylinders for responsive steering and performance. An electronic secondary steering system is standard.

**Hydraulic Steering Cushioning System.** The 740 Ejector incorporates a hydraulic cushioning system, resulting in smooth, responsive steering. It also increases operator comfort and reduces shock loads to the machine components.

## Performance and Productivity – Ejector

*Designed to disperse the load on-the-go for faster cycle times and lower spreading costs.*

**Ejector.** The 740 Ejector is designed to disperse the load on-the-go for faster cycle times and lower spreading costs. The ejector body also offers clean load ejection and the capability to work in areas with restricted overhead clearance and soft underfoot conditions.

**Versatility.** The 740 Ejector is based on the standard 740 Articulated Truck and shares all its versatility. It can operate in the same conditions, yet offers a number of unique capabilities that stretch the operation envelope.

**Spreading.** The truck can eject the material and spread it out while moving, reducing the size of additional spreading and dozing equipment. This makes the 740 Ejector an ideal solution for road building and landfill applications. On-the-go ejecting results in faster cycle times and reduced power train loads.

**Stability.** Ejecting the load without raising the body increases stability, allowing load dispersal on inclines, side slopes and in very soft underfoot conditions. Generally, these conditions would be unacceptable with a conventional truck, but are ideal for the 740 Ejector, especially on landfill sites.

**Overhead Clearance.** Because the body is not raised when ejecting the load, the truck can be utilized in areas with reduced overhead clearance such as when working around overhead lines, conveyors, hoppers and bridges. The ejector is also ideal for tunneling and underground operations.

**Carry-Back.** The design of the ejector is inherently self-cleaning and practically eliminates material sticking to the body, which increases productivity, improves fuel efficiency and lowers cost per ton.



**Body.** Reinforced body is made from thick high-yield, heat-treated steel that provides exceptional durability. Ejector top rails are made from high-strength alloy steel identical to the Cat 769D Off-Highway Truck. For optimum durability and wear life, the ejector body is designed to work in applications where the material consists of rocks smaller than 152 mm (6 in) in diameter.

**Blade.** The ejector blade is made from high-strength steel and uses technology similar to that proven in Cat wheel tractor-scrapers.

**Cylinder.** A four-stage, high-speed, double-acting cylinder is specifically designed for horizontal mounting and provides smooth load ejection. It is centrally supported and nitride-hardened to ensure a long service life.

**Proven Technology.** Much of the 740 Ejector design is carried over from the Cat 740 Articulated Truck.

## Ease of Operation

*Designed for simple, easy operation, the 740 Ejector allows the operator to focus on production.*



**Ergonomic Layout.** The controls and layout of the cab are designed to make it as easy to operate as your car. Quick and easy to read and simple to operate, the controls on the 740 Ejector allow the operator to concentrate on production.

**Dash.** The wrap-around dash puts all controls within easy reach of the operator. It provides an automotive feel with the industrial strength you would expect from Caterpillar.

**Viewing Area.** The low sloping hood and placement of the cooling package behind the cab give the operator excellent all-around visibility. The large glass area and central operator position also provide excellent visibility.

**Wipers.** The wet arm wiper system cleans more glass area and is bottom-mounted to keep it out of the operator's line of sight. Windows are tinted to reduce glare.

**Differential Lock Controls.** The switch for the inter-axle differential lock is positioned in the operator's footrest for ease of operation. An additional dash-mounted switch is all that is required to select full driveline lock-up. Disengaging the foot switch opens all differential locks immediately.

**Retardation Control.** The Cat engine compression brake control lever is positioned on the right-hand side of the steer column. Four modes of operation, with three steps of retardation, provide an optimum match between operating conditions and retarding power.

### **Transmission and Ejector Levers.**

Finger tip controls allow easy operation and low effort. The ejector and transmission levers are positioned for easy, comfortable operation, along with the control for top gear limit, transmission hold and neutral lock.

### **Safe Start Mode (Neutral Start).**

The transmission lever must be in neutral and the hoist lever must be in hold before the engine will start.

**Blade Retraction Sequence.** The ejector blade returns to the loading position as soon as the blade retract sequence is initiated. The transmission is held in the gear selected for the ejecting cycle until this sequence is completed and the ejector control lever is returned to the float position.

**Suspended Pedals.** Easy to operate and reach with plenty of leg and foot room. They also make for easier cleaning of the cab floor by keeping the pedals out of the dirt.

**Cat 2S Monitoring System.** Provides an improved method of monitoring critical machine functions and alerts the operator to an immediate or impending problem. The system provides four levels of warning:

**Level 1** – Be aware.

**Level 2** – Change machine operation or perform maintenance.

**Level 2S** – Immediate change in operation required.

**Level 3** – Safe machine shutdown required.

## Operator Comfort

*The operator's office – high productivity from a comfortable, motivated operator.*

**Ride Comfort.** The three-point front suspension with its oscillating axle and low-pressure ride struts, combined with the center-mounted cab, offers unrivaled levels of ride comfort for the operator in all driving conditions. The operator remains comfortable and productive throughout the day.

**Spacious Two-Person Cab.** The 740 Ejector features a large two-person cab, offering a comfortable working space for both the operator and trainer or trainee. All 700 Family articulated trucks use the same spacious cab design.

**Air Suspension Seat.** Enhances operator comfort with a dual-sided support recliner and thicker cushions. It is fully adjustable to provide an optimal driving position.

**Storage Space.** Plenty of storage space to create a secure and uncluttered working environment.

**Trainer Seat.** Full-size trainer seat features a fully padded seat with a backrest and a wide, retractable seatbelt for a secure and comfortable ride. The trainer seat is positioned next to the operator seat, giving both the operator and trainer a clear view of the instrument panel, controls and the road.

**Heating/Ventilation/Air Conditioning.** Twelve vents provide air distribution to keep the operator comfortable and to provide rapid defrosting of all windows. Heating, air conditioning and defrosting are standard and the recirculation filter is positioned for easy servicing.



**Radiator Mounting.** The radiator is mounted at an angle to prevent heat transfer to the cab.

**Dual-Sliding Window.** The right-hand window is a dual sliding window. Opening this window with the left rear-hinged window provides cross-flow ventilation and enhanced operator comfort.

**Sound Levels.** Cab mounts are designed to reduce noise and vibration in the cab. All connections to the cab are resiliently mounted. The operator's station makes extensive use of sound absorbing and barrier materials to keep sound levels low.

**Steering Column.** Offers telescopic and tilt features to provide a comfortable driving position.

## Serviceability

*More time on production, less time and money spent on servicing.*



**Long Service Intervals.** Long engine oil change and hydraulic oil change intervals lower maintenance costs and downtime. Wheel-bearing adjustment is completely eliminated.

**Test and Lube Points.** Test points are grouped together behind the cab and accessible from the ground. Lube points are grouped at the rear of the front frame and the front of the rear frame. Autolube is optional.

**Service Points.** Engine and transmission dipstick and fill caps, air and fuel filters and the fuel priming pump are all mounted on the left side of the engine under the hood. Coolant level indicator and fill caps are outside the cab.

**Radiator.** The radiator package is located behind the cab, which provides easy access to the inlet and outlet sides of the radiator. The ATAAC radiator is located at the front of the truck.

**Extended Life Coolant.** Extends the change interval and improves water pump life by reducing aluminum corrosion.

**Hood.** The hood is raised and lowered electrically requiring minimal operator effort when servicing.

**Electrical Service Center.** Located inside the cab, this service center provides a power port, diagnostic connector and the Cat Data Link connector.

### **Cat Data Link Connector.**

Provides a connection point for a laptop computer running Electronic Technician (ET) software. The Cat Data Link port performs programming functions on all electronic controls.

**Service Access.** The cab tilts to the side to provide easy access underneath, which simplifies servicing of the transmission, drive shafts and hydraulic pumps. Machine electrical and hydraulic interfaces are located on the right side of the cab, behind a removable cab body panel for easy access.

### **Integrated Transmission Package.**

The transmission integrates the transmission pump, torque converter and four pump drives into a single package. Because the transmission is an integral design, it eliminates many of the external hoses, resulting in less servicing and higher reliability.

### **Engine and Transmission Removal.**

The front frame design allows the engine and transmission to be removed and installed in one piece.

**Truck Transport.** The suspension system eliminates the need to lower the suspension when transporting the truck, reducing maintenance and downtime.

**Output Transfer Gear.** Provides lubrication of all bearings and clutches using a distributed-pressure lubricated and filtered system. Better lubrication and filtration reduce service and repair.

## Durability and Reliability

*High availability leads to high productivity.*

**Front Frame.** The front frame design features a large box-section, and wide, stiff frame beams to handle torque loads. The divergent frame design decreases stress in the hitch area and optimizes suspension geometry. The frame has been designed to make maximum use of robotic welding for increased durability.

**Rear Frame.** Twin-box construction minimizes stress concentration and provides low weight with long service life.

**Castings.** The front and rear frames make extensive use of heavy-duty steel castings to handle stress concentrations.

**Front Suspension.** Three-point front suspension provides unparalleled ride quality. It also protects the truck from the most adverse road conditions by absorbing shock loads that would otherwise reach the frame.

**Service Brakes.** Oil-cooled, multiple disc brakes are continuously cooled for exceptional, non-fading braking. They are designed and built for reliable, adjustment-free operation.

**Parking Brake.** Located on the center axle in an elevated position out of the dirt and designed to deliver higher heat capacity and abuse resistance.

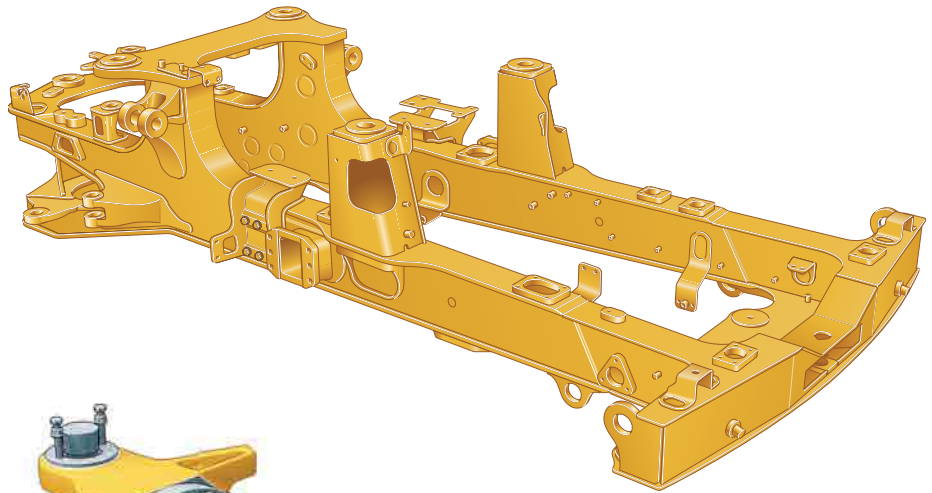

### **Articulating/Oscillating Hitch.**

The articulating hitch provides the truck with steering articulation and the oscillation ensures the truck maintains all-wheel ground contact in rough terrain.

### **Steer Cylinders In-Line with Hitch.**

Steer cylinders are in-line with the hitch, minimizing steer loads and stress in the hitch area.

### **Hitch Construction.**

Two-piece hitch construction features a strong, durable cast steel head bolted to a hard wearing forged steel tube. The hitch tube has large, hardened bearing areas and a hardened thrust face for reduced maintenance and longer life.

**Cat Power Train Components.** All major components have been purpose-designed for earthmoving applications. In fact, many of the major components have been designed specifically for articulated trucks.

**Radiator Protection.** The radiator is located behind the cab for improved visibility. This design incorporates three levels of protection:

- 1) Body Spill Guard.**
- 2) Cab Steel Spill Guard.**
- 3) High-Strength Surround.**

## Engine

Cat C15 with ACERT Technology	
Gross Power	
SAE J1995	341 kW/464 hp
Net Power at 1700 rpm	
ISO 9249	327 kW/445 hp
EEC 80/1269	327 kW/445 hp
Bore	137 mm
Stroke	171.5 mm
Displacement	15.2 liter

- All engine horsepower (hp) are metric including front page.
- The net power advertised is the power available at the flywheel when the engine is equipped with alternator, air cleaner, muffler and fan at minimum speed.
- Net power when the fan is at maximum speed is 315 kW per the SAE reference conditions.
- The 740 Ejector meets EU Stage IIIA emission specifications for Europe through 2010.
- No engine derating required below 2438 m.

## Transmission

Forward	km/h
1	8.9
2	12.1
3	16.4
4	22.0
5	29.9
6	40.3
7	54.7
Reverse	
1	8.4
2	11.6

## Weights

Rated Payload	38 000 kg
---------------	-----------

## Operating Weights

Empty	kg
Front Axle	19 800
Center Axle	8240
Rear Axle	7570
Total	35 610

Rated Load	
Front Axle	1640
Center Axle	18 180
Rear Axle	18 180
Total	38 000

Loaded	
Front Axle	21 440
Center Axle	26 420
Rear Axle	25 750
Total	73 610

## Body Capacities

	m <sup>3</sup>
Heaped SAE 2:1	23.1
Struck	17.8
Heaped SAE 1:1	28.5

## Ejector Cycle Times

Eject Time	14 Seconds
Retract Time	24 Seconds
Flow Rate	415 L/min

## Body Plate Thickness

Front	6 mm
Side	6 mm
Base	10 mm

## Brakes

ISO 3450:1998

## ROPS/FOPS Cab

Cab/FOPS	ISO 3449:1992 Level II
Cab/ROPS	ISO 3471:1994

## Sound

### Interior Cab – Operator Sound

The operator sound level measured according to the procedures specified in ISO 6394 is 79 dB(A), for cab offered by Caterpillar, when properly installed and maintained and tested with the doors and windows closed.

### Exterior Sound

The European Union 2000/14/EC labeled spectator sound power level is 113 dB(A).

## Service Refill Capacities

	Liter
Fuel Tank	560
Cooling System	80
Hydraulic System	233
Engine Crankcase	38
Transmission	72
Final Drives/Differential	80
Output Transfer Gear Box	21

## Dimensions

All dimensions are approximate.

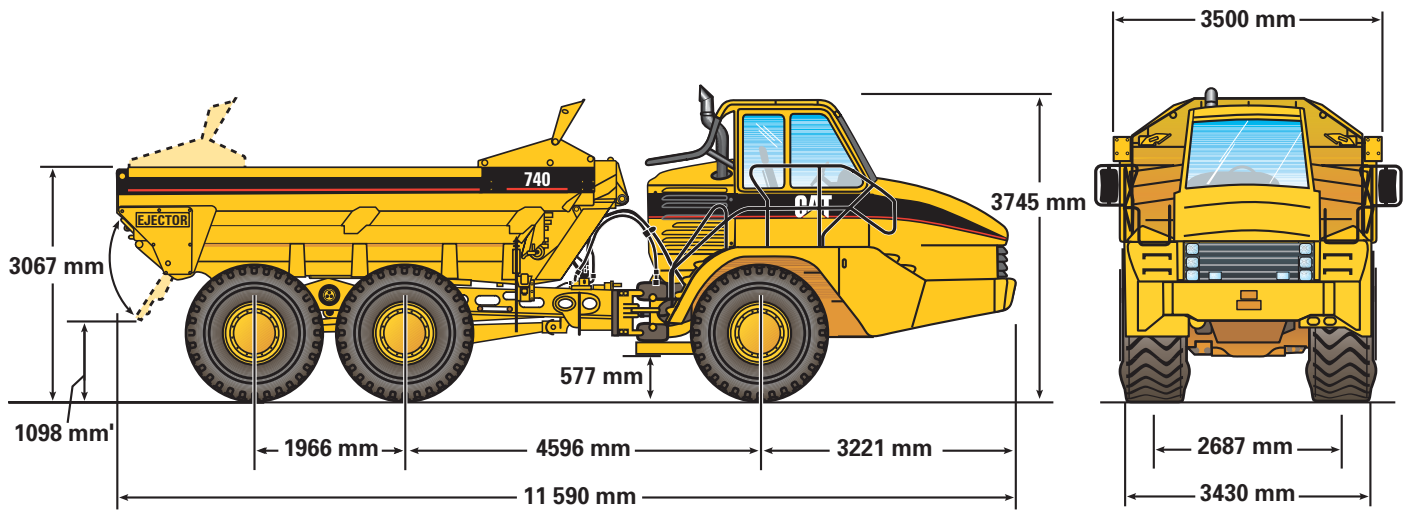

## Turning Circle

Dimensions are for machines equipped with 29.5R25 tires.

### Turning dimensions

Steer angle – left/right	45°
SAE turning radius	8640 mm
Clearing radius	9090 mm
Inside radius	4470 mm
Aisle width	5930 mm

### Steering

Lock to lock	5 seconds
Flow rate	190 l/min

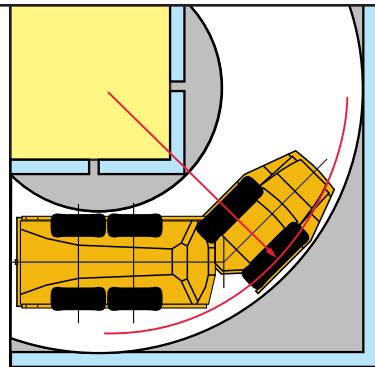

## Optimal Loader/Truck Pass Matching

Hydraulic Excavators	385C	365C	345C	
Loader Capacity (metric tons) – 50 min/h	954-1193	750-1100	665-805	
Passes	4	5	6-7	
Wheel Loaders	988H	980G II	972G II	966G II
Loader Capacity (metric tons) – 50 min/h	565-790	590-650	490-565	400-535
Passes	3-4	4	5	6

An optimum system match gives you a major productivity advantage. The 740 Ejector is an excellent match for the Cat 385C, 365C and 345C Hydraulic Excavators; and Cat 966G II, 972G II, 980G II and 988H Wheel Loaders. This results in increased production and lower system costs per unit of volume moved.

## Gradeability/Speed/Rimpull

To determine performance, read from Gross Weight down to % Total Resistance. Total Resistance equals actual % grade plus 1% for each 10 kg/metric ton of Rolling Resistance. From this point, read horizontally to the curve with the highest attainable speed range. Then, go down to Maximum Speed. Usable Rimpull depends on traction available.

- E** Empty 35 610 kg
- L** Loaded 73 610 kg
- 1A** 1st Gear (Converter Drive)
- 1B** 1st Gear (Direct Drive)
- 2** 2nd Gear
- 3** 3rd Gear
- 4** 4th Gear
- 5** 5th Gear
- 6** 6th Gear
- 7** 7th Gear

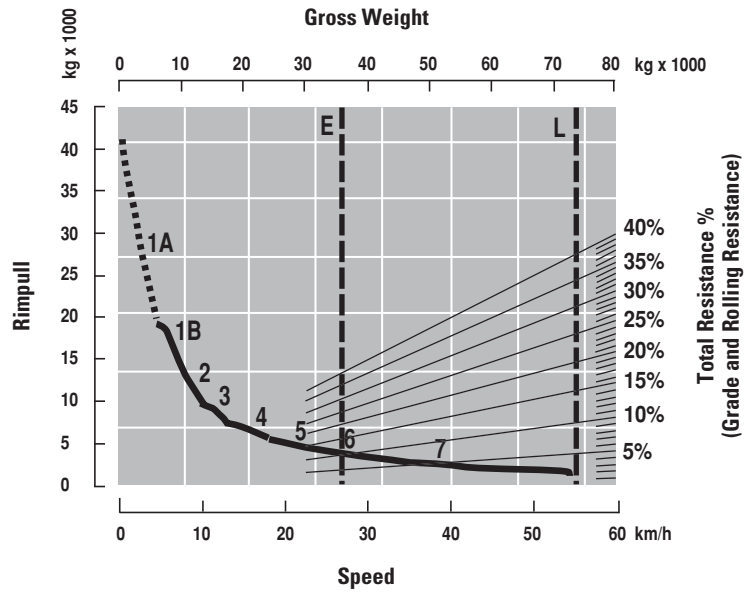

## Retarding Performance

To determine performance, read from Gross Weight down to % Effective Grade. Effective Grade equals actual % favorable grade plus 1% for each 10 kg/metric ton of Rolling Resistance. From this point, read horizontally to the curve with the highest attainable speed range. Then, go down to Maximum Speed. Retarding effect on these curves represents full application of the retarder.

- E** Empty 35 610 kg
- L** Loaded 73 610 kg
- 1** 1st Gear
- 2** 2nd Gear
- 3** 3rd Gear
- 4** 4th Gear
- 5** 5th Gear
- 6** 6th Gear
- 7** 7th Gear

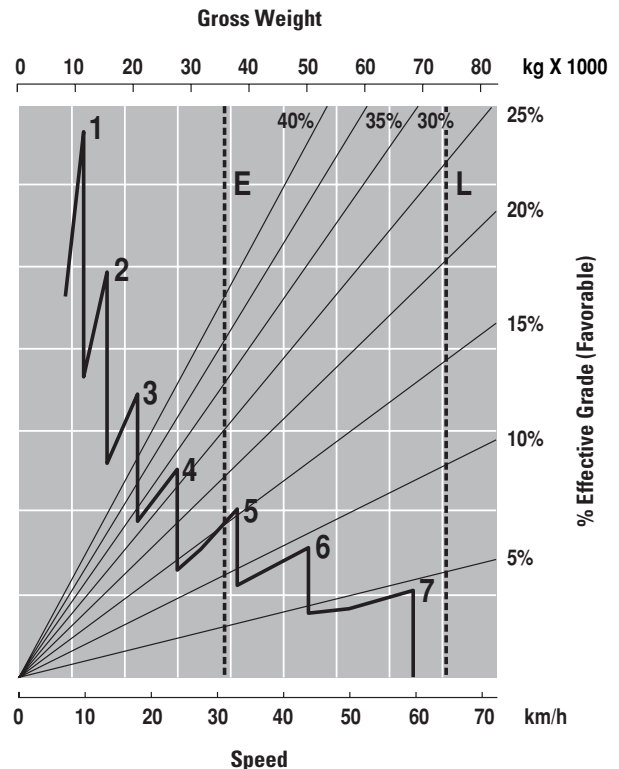

---

## Standard Equipment

Standard equipment may vary. Consult your Caterpillar dealer for details.

---

Air conditioning with R134A refrigerant  
Air vents, adjustable  
Auto shift seven-speed forward and two-speed reverse transmission  
Back up alarm  
Body, adapted for exhaust heat  
Cat C15 engine with ACERT Technology  
Differentials, standard with clutched cross-axle differential locks for all axles  
Electrical system: 24 volt, 5A 24- to 12-volt converter  
Electro hydraulic hoist control  
Engine compression brake  
Ether starting aid  
Glass windows, laminated and tinted, front  
Glass windows, toughened and tinted, sides and rear  
Guards: rear window and radiator, crankcase and axle  
Headlights, four with dimmer switch  
Heater and defroster with four-speed fan  
Horn, electric  
Lights: cab interior, front, side, rear, two reversing/working lights, two stop/tail lights

Mirrors, main and auxiliary, left and right  
Mud flaps, body mounted  
Oil-cooled brakes, enclosed  
Radio Ready  
ROPS/FOPS cab, with full instrumentation, including:  
– Instrument cluster display module  
– Indicator lamps: left turn, secondary steering, primary steering loss, front and rear brake temp (735/740 and 740 Ejector only), brake oil pressure, action lamp, transmission fault, park brake, charging system status, differential lock, body not in float, right turn, spare, high beam, transmission hold, machine filter warning, retarder, retarder up shift warning  
– Gauges: engine oil pressure, engine coolant temperature, torque converter oil temperature, fuel level, fuel tank level gauge  
– Meters: service hour meter, speedometer, tachometer

Seat, fully adjustable, air suspension  
Seat, padded companion/trainer  
Seatbelts, two retractable  
Secondary steering  
S•O•S sampling valves  
Starting receptacle, electric, remote  
Storage – two cup holders, flask receptacle, under seat storage, door pocket, behind seat storage, coat hook  
Sun visor  
Three-axle, six wheel drive  
Tilt and telescopic steering wheel  
Tires, 29.5R25, radial  
Tow pins, front and rear  
Vandalism protection: lockable caps for fuel tank, hydraulic oil tank and radiator  
Windows opening side, tinted  
Windshield wiper and washer, two speed, intermittent (front)  
Windshield wiper and washer, two speed, (rear)

---

## Optional Equipment

Optional equipment may vary. Consult your Caterpillar dealer for details.

---

Autolube installation for automatic greasing of bearings  
Cold start kit  
Cycle counter/operator monitoring kit  
Extensions, fender  
Fast fuel fill  
Heated rearview mirrors  
Sound suppression spectator  
Tires, optional tire sizes and tread patterns available

### Field-Installed Attachments – Dealer

The following attachments can be ordered from Parts Distribution:  
– 173-6530 Radio 12V AM/FM  
– 173-6532 Radio 12V AM/FM Deluxe  
– 214-7318 Tool Kit and Box  
– Ether start canister

# 740 Ejector Articulated Truck

HEHM5650 (05/2005) hr

Materials and specifications are subject to change without notice.  
Featured machines in photos may include additional equipment.  
See your Caterpillar dealer for available options.

[www.CAT.com](http://www.CAT.com)

© 2005 Caterpillar  
All rights reserved

**CATERPILLAR**<sup>®</sup>