

583T

Pipelayer



Engine

Engine Model	Cat® C15 ACERT™	
Gross Power	259 kW	347 hp
Flywheel Power	231 kW	310 hp

- Engine ratings at 1,850 RPM

Weights

Operating Weight	45 359 kg	100,000 lb
Shipping Weight	44 906 kg	99,000 lb

- Operating weight includes all shipping weights plus full fuel tank and operator.
- Shipping weight includes: lubricants, coolant, 10% fuel, hydraulic controls and fluids, backup alarm, seat belt, 710 mm (28") grouser shoes, drawbar and counterweight.

Operating Specifications

Lifting Capacity	63 504 kg	140,000 lb
------------------	-----------	------------

583T Pipelayer

The 583T Pipelayer offers outstanding productivity.

Pipelayer

Fully hydraulic load line and boom winches provide excellent controllability for precise pipe placement. Counterweight and frame design provides excellent stability. **pg. 4**

Structure

Mainframe is heavy, strong and durable. Full box sections, steel castings and continuous rolled rails provide durable support to the undercarriage, elevated final drives and other integral frame components. **pg. 5**

Operator Station

✓ Designed for operator comfort, convenience and productivity. Machine control and vital information is provided at the operator's fingertips. A full day of work is no problem in this efficient work place. **pg. 6**

Undercarriage

The proven elevated sprocket undercarriage isolates the drive train components from ground-induced impacts. Designed to optimize machine balance for best possible performance and extended component life. **pg. 11**

Serviceability and Customer Support

Combining easy to access, modular components with your Caterpillar® Dealer's advanced rebuild and repair capabilities ensures rapid component replacement and minimum downtime. **pg. 12**

Engineered for reliable production in the toughest conditions. The 583T's high horsepower and rugged components are designed for tough and varied working conditions. This machine offers the reliability and durability expected from Cat® Pipelayers.



Optional Enclosed Cab

- ✓ The optional enclosed cab offers operator comfort in any climate. The operator enjoys excellent visibility in all directions because the cab was designed with maximum glass area and includes a skylight window to view the boom and upper block. **pg. 7**

Power Train

- ✓ The rugged, easy-to-service Cat® C15 engine with ACERT™ Technology has a high torque rise and meets worldwide emissions regulations. **pg. 8**

Drive Train

- ✓ The electronically controlled power shift transmission, efficient differential steering and durable planetary final drives deliver outstanding power transfer and long life to ensure maximum productivity. **pg. 10**



✓ *New Feature*

Pipelayer

Caterpillar pipelayer system includes winch, boom, hook, counterweight and frame.



Winches.

- Boom and hook drawworks are driven by independent hydraulic winches.
- Oil-disc brakes provide smooth operation and positive retention of boom and hook positions.
- Modular design allows fast replacement, easy field service and testing.
- High parts interchangeability between hook and boom winch assemblies.
- Infinitely variable speed controls for both boom and hook allow precise control.
- Emergency free-fall function on hook line control allows the operator to drop the load quickly.



Counterweight and Frame.

- Counterweight is extended hydraulically for improved load balance and clearance.
- Counterweight segments are contoured to provide a low center of gravity and enhanced forward and right side viewing area. Segments are splined to the counterweight assembly for ease of assembly and disassembly.

Drawbar.

- Able to tow wide range of attachments.



Blocks and Hook. Heavy-duty lifting components include the following: Load and boom blocks, forged hook with latch, serviceable handle, roller bearings and ductile iron sheaves with sealed roller bearings. Also includes high performance cable for improved life, crush resistance, flexibility and strength.

Boom.

- 7.3 m (24 ft) Boom is standard equipment with large box section.
- Replaceable, boom-mount bearings.
- High tensile strength steel construction.
- Allows for smaller sections for improved visibility.
- Lighter weight for increased payload.
- Durable for long life.

Structure

Engineered to provide durability and the solid support necessary for maximum production and service life in the most demanding conditions.



Mainframe Strength. The 583T mainframe is built to absorb high impact shock loads and twisting forces.

Frame Rails. Full box section, designed to keep components rigidly aligned.

Heavy Steel Castings. Adds strength to the main case, center saddle and front cross member.

Top and Bottom Rails. Continuous rolled sections, with no machining or welding, to provide superior mainframe durability.

Main Case. Elevates the final drives well above the ground level work area to protect them from impact loads, abrasion and contaminants.

Robotic Welding. Caterpillar uses robotic welding techniques in the assembly of the case and frames. This insures quality and reliability throughout the structure. Robotic welding provides deep penetration and consistency for long life, and reduces the chance for errors that may be made during manual welding.

Roller Frames. Roller frames are tubular, to resist bending and twisting, with reinforcement where operating stresses are the highest.

- Non-oscillating roller frames for greater stability in pipelaying applications.
- The recoil system is sealed and lubricated.



Front Bumper. A front bumper is pinned on the frame rails and provides both protection and a towing device. Pipelayer frame mounts are also an integral part of the frame.



Optional Rollover Protective Structure. Provides increased operator protection.

- Available with or without cab.

Operator Station

Excellent operator visibility with ergonomically designed operator station for maximum comfort and productivity.



Clear Full-Circle View. A tapered hood and “notched” fuel tank give the operator a clear line of sight to the front, rear and side work areas. The new streamlined design of the Caterpillar 583T Pipelayer offers several operator visibility improvements for more precise maneuvering and placement of pipe.



Steering Control. Dual-twist tiller control with standard differential steering controls direction and degree of turns, forward-reverse shifting, and gear selection in a single control handle. One hand steering enhances operator comfort.

Cat Comfort Series Seat. Ergonomically designed and fully adjustable for maximum comfort.

- Seat cushion reduces the pressure on the lower back and thighs while allowing unrestricted arm and leg movement.
- Seat is raised and moved to the left providing improved all around visibility.



Ergonomic Work Tool Controls. Pipelayer controls are low effort and allow simultaneous, precise positioning of the load line and boom with one hand.

Monitoring System. Provides the operator instant feedback on the condition of operating systems and records such performance data as high/low gauge readings to help diagnose problems and manage undercarriage. Has gauges that monitor the temperature of the engine coolant, hydraulic oil and power train oil, plus the fuel level. Also has a digital and gauge type tachometer.



Access Ladder. Direct access to the operator's station utilizing ladder on left side of the machine.

Variable Load Line Speed Range. Allows the operator to regulate line speed.

Power Supply. The voltage converter provides two 12-volt power supplies.

Counterweight Control. Adjusts the position of the counterweight for added machine stability.

Engine Speed Control. A rocker switch and decelerator pedal control engine speed. Idle can be set to desired level. High or low idle is delivered with a touch of the finger.

Optional Enclosed Cab

Caterpillar® offers an optional enclosed cab to maximize operator comfort in any climate.

Optional Enclosed Cab. Designed for operator comfort and productivity in any climate. Fully insulated with a heater. Air conditioning and ROPS available as additional options.

Excellent Visibility. The optional cab provides excellent visibility, designed with the maximum glass area. There is also an additional option of dual pane windows available for cold weather environments.

Skylight Window. The cab is equipped with a skylight window to view the boom and upper block.

Screened Side Windows. The side windows are screened to allow better ventilation and ground communication.

Wipers. The optional cab is equipped with wipers on the front, rear and door windows to provide a clearer view during inclement weather.

Lights. Eight additional halogen lights come with the cab arrangement, 3 facing forward, 2 to the rear, 2 to the boom side and 1 to the winch side.



Power Train

The rugged, easy-to-service Cat C15 engine with ACERT™ Technology has a high torque rise and meets worldwide emissions regulations.



Engine. The Cat C15 engine with ACERT™ Technology provides the power for the 583T. Performing at full-rated net power of 231 kW (310 hp) at 1,850 rpm, the large displacement and high torque rise provides the 583T the power needed on challenging jobs. Matched to the high-efficiency torque divider and electronically controlled power shift transmission, it will provide years of dependable service.

C15 Block. The one-piece, grey iron block features generous ribbing for stiffness and heavy bearing bulkheads for rigidity and strength. Incorporation of straight o-ring connection points reduces the loss of engine oil and fluids.

Constant Net Horsepower.

- Constant net horsepower allows the operator to maintain high standards of performance and response, even when parasitic loads, such as the on-demand cooling fan, are applied.
- Engine automatically adjusts to maintain power output and conversely lowers output when demands are low.
- Significant fuel savings in cooler climates and during long engine idle times typical of pipeline applications.

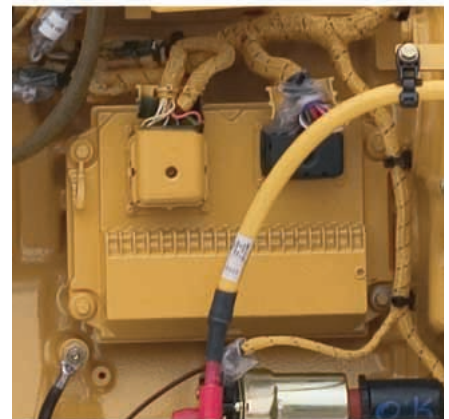

ADEM™ A4 Engine Controller.

The ADEM A4 electronic control module manages fuel delivery to get the best performance per liter (gal) of fuel used. It provides flexible fuel mapping, allowing the engine to respond quickly to varying application needs. It tracks engine and machine conditions while keeping the engine operating at peak efficiency.

Fuel Delivery. Multiple injection fuel delivery involves a high degree of precision. Precisely shaping the combustion cycle lowers combustion chamber temperatures generating fewer emissions and optimizing fuel combustion; translating into more work output for your fuel cost.

MEUI Fuel System. A highly evolved fuel system with a proven record of reliability in the field. MEUI combines the technical advancement of an electronic control system with the simplicity of direct mechanically controlled unit fuel injection. The MEUI system excels in its ability to control injection pressure over the entire engine operating speed range. These features allow the C15 to have complete control over injection timing, duration, and pressure.

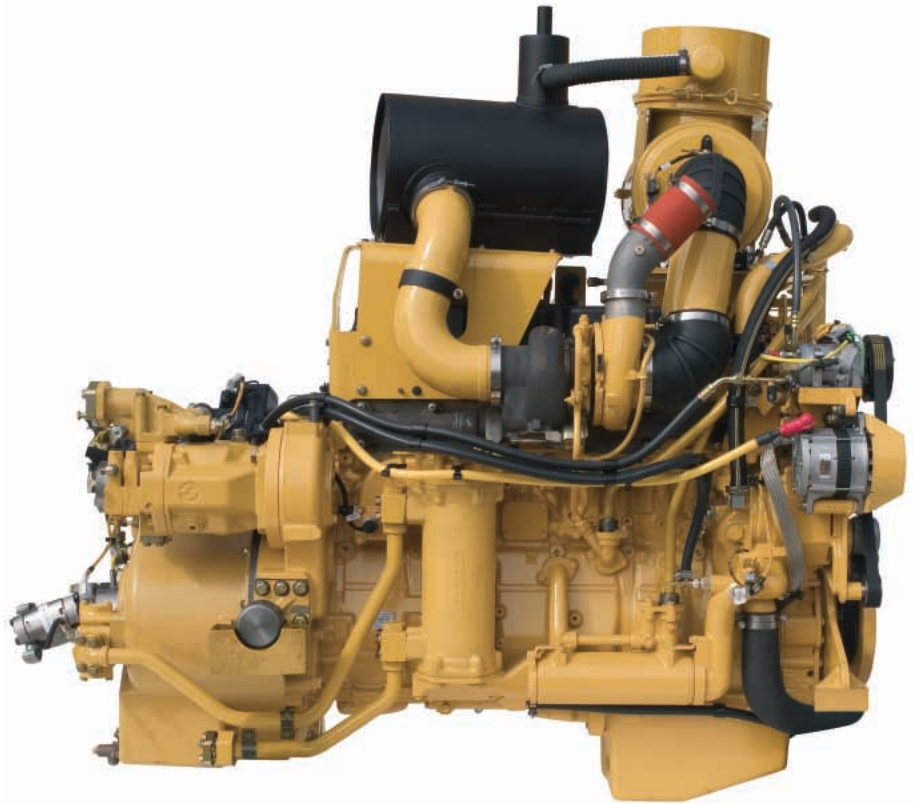

ATAAC and Turbocharging.

Air-to-air aftercooling keeps air intake temperatures down and, in concert with the tight tolerance combustion chamber components, maximizes fuel efficiency and minimizes emissions. Significant improvements in air flow are generated by a water-cooled turbocharger, unique cross-flow head and single overhead cam.

Service. Easier maintenance and repair through monitoring key functions and logging critical indicators. Electronic diagnostic access is possible with a single tool, the Cat Electronic Technician.

Drive Train

The drive train provides maximum efficiency in combination with the C15 engine with ACERT™ Technology.

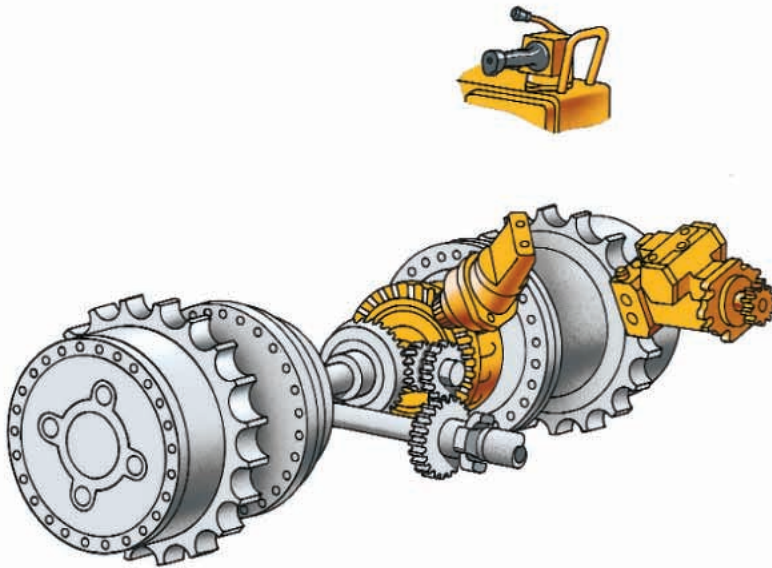

Differential Steering System. A planetary differential turns the machine by speeding up one track and slowing the other, while maintaining full power to both. The system consists of three planetary gear sets.

- Provides enhanced side slope capability.
- Two planetary gear sets (steering and drive) make up the “dual differential,” which performs the traditional drive function (forward or reverse). Unlike competitive machines, the differential also performs a steering function with input from the steering motor.
- A third planetary gear set, the “equalizing planetary,” resides inside the transmission case. It is connected to the dual differential, which provides a maximum speed difference between the right and left final drives during a turn.
- A dedicated variable-displacement hydraulic pump.
- A bi-directional, fixed-displacement steering motor.
- Heavy-duty steering drive gears.

Planetary Power Shift Transmission.

Three speeds forward and three speeds reverse, utilizing large diameter, high capacity, oil-cooled clutches.

- Modulation system permits fast speed and direction changes.
- Modular transmission and differential slide into rear case for servicing ease.
- Oil-to-water cooler for maximum cooling capacity.
- Forced oil flow lubricates and cools clutch packs to provide maximum clutch life.

Elevated Final Drives.

- Isolated from ground and equipment induced impact loads for extended power train life.
- Crown-shaped drive gears provide smooth, quiet, low maintenance operation.
- Splash lubrication and Duo-Cone™ Seals extend service life



Torque Divider. A high efficiency torque divider with freewheel stator provides high torque multiplication while shielding the drive train from sudden torque shocks and vibration.

Power Shift with Differential Steer

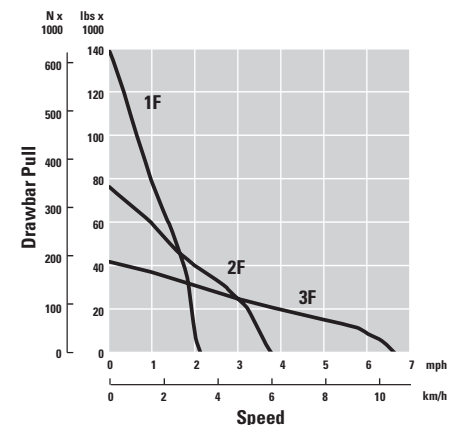

Drawbar vs. Speed. As loads on the tractor increase, the 583T offers unmatched lugging capability and smooth shifting as the need occurs to change gears under varying loads. The 3-speed forward, 3-speed reverse transmission, backed by differential steering, offers excellent runout speeds and accurate steering capability under load.

Undercarriage

The Caterpillar elevated sprocket undercarriage is designed for optimized machine balance and best possible performance and extended component life.



Final Drives. Final drives and associated power train components are raised above the work area, isolating them from ground induced impact loads, as well as pipelayer loads, extending power train component life.

Sprockets. Sprocket position keeps sprocket teeth, bushings and final drives away from the abrasive materials and moisture, resulting in longer final drive gear and seal life.

Rollers and Idlers. Feature symmetric Duo-Cone seals for long sealing life to prevent oil loss and dirt entry. Toric rings maintain performance over a wide range of temperatures. Rollers and idlers are serviceable and rebuildable to provide value.

Roller Frames. Roller frames are tubular to resist bending and twisting, with added reinforcement where operating loads are highest.

Sprocket Segments. Made exclusively of Caterpillar Tough Steel™ for longer wear life and precision machined after heat treat for proper fit. Segments can be removed or replaced without breaking the track.

Track Shoes. Track shoes are 710 mm (28 in) single grouser design and made from heat treated, rolled steel for added strength. Wide track and clipped shoes are available as an option to match working conditions. Long track frame and wide gauge enhance track contact area, providing a stable working base.

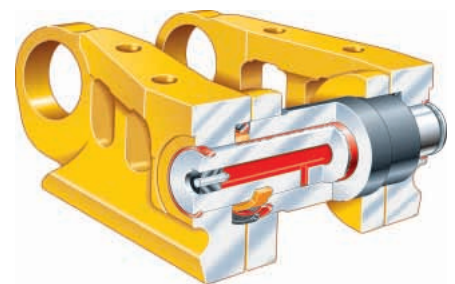

Positive Pin Retention (PPR) Sealed and Lubricated Track. Designed for high-impact and high load applications. The PPR exclusive Caterpillar design locks the link to the pin.

Serviceability and Customer Support

World-class product support. The most serviceable machines from the most committed dealers. The Cat Dealer network trained experts keep your fleet up and running, maximizing your equipment investments. Caterpillar. The difference counts.™



Serviceability. Minimizes maintenance and repair downtime. New sight gauges, filter locations, improved access to oil and coolant sampling ports, and an engine compartment mounted work lamp, make daily and periodic service faster and easier.

Engine Oil Filter. Engine oil filter is located on the engine for easy servicing access and minimal downtime. Save further time with the optional quick oil change attachments.

Water Separator and Fuel Filter. Easily located just inside the engine access panel, the water separator functions as the primary fuel filter, just ahead of the secondary fuel filter.

Quick Disconnect Fittings. Allow for fast diagnosis of the power train, hydraulics and attachment oil systems.

S•O•SSM Analysis. Scheduled Oil Sampling made easier through live sampling ports for the engine oil, hydraulics and coolant.

Caterpillar Product Link PL300 (optional). This option allows the customer or dealer to obtain machine diagnostics and location information from their offices. Product Link PL300 provides updates on service meter hours, machine condition and machine location, as well as integrated mapping/route planning. Built-in flexibility allows for future technology development.

Purchase. Consider the financing options available, as well as day-to-day operating costs. This is also the time to look at dealer services that can be included in the cost of the machine to yield lower equipment owning and operating costs over the long run.

Product Support. Plan for effective maintenance before buying equipment. Choose from your dealer's wide range of maintenance services at the time you purchase your machine. Programs such as Custom Track Service (CTS), S•O•S analysis, Technical Analysis and guaranteed maintenance contracts give peak life and performance to your machine.



Parts Program. You will find nearly all parts at your dealer parts counter. Cat Dealers use a worldwide computer network to find in-stock parts to minimize machine downtime. Ask about your Cat Dealer's exchange program for major components. This can shorten repair time and lower costs.

Remanufactured Components. Genuine Cat Remanufactured parts save you money. You receive the same warranty and reliability as new products at cost savings of 40 to 70 percent. Components available for the drive train, engine, and hydraulics.

Engine

Engine Model	Cat® C15 ACERT™	
Gross Power	259 kW	347 hp
Flywheel Power	231 kW	310 hp
Net Power – Cat	231 kW	310 hp
Net Power – ISO 9249	231 kW	310 hp
Net Power – SAE J1349	229 kW	307 hp
Net Power – EU 80/1269	231 kW	310 hp
Bore	137 mm	5.4 in
Stroke	172 mm	6.75 in
Displacement	15.2 L	928 in ³

- Engine ratings at 1,850 RPM
- Net power advertised is the power available at the flywheel when the engine is equipped with fan, air cleaner, muffler and alternator
- No engine derating required up to 3658 m (12,000 ft). Automatic derating occurs beyond that altitude.

Undercarriage

Shoe Type	Moderate Service	
Width of standard shoes	710 mm	28 in
Number of shoes (each side)	47	
Grouser Height	78 mm	3 in
Track gauge	2337 mm	92 in
Length of track on ground	3587 mm	141 in
Ground contact area with 710 mm (28") shoes	5.1 m ²	7,896 in ²
Number of rollers (each side)	9	
Number of Carrier Rollers	1 per side	

- Positive pin retention track

Hydraulic System

Pump Type	Piston-type, Variable, two section	
Pump output – max	540 L/min	142 gal/min
Relief Valve Setting – Counterweight	17 225 kPa	3,000 psi
Pump output – steering	27.6 L/min	7.3 gal/min
Pump Output – Counterweight (gear)	98 L/min	25.9 gal/min

Service Capacities

Fuel Tank	408.8 L	108 gal
Crankcase and filter	38 L	10 gal
Final drive (each side)	12.8 L	3.4 gal
Cooling system	77 L	20.3 gal
Hydraulic tank	96.5 L	25.5 gal
Power Train	155 L	41 gal
Roller Frames (each)	71.9 L	19 gal
Variable Fan Hub	3.1 L	0.82 gal

Operating Specifications

Lifting Capacity	63 504 kg	140,000 lb
------------------	-----------	------------

Weights

Operating Weight	45 359 kg	100,000 lb
Shipping Weight	44 906 kg	99,000 lb

- Operating weight includes all shipping weights plus full fuel tank and operator.
- Shipping weight includes: lubricants, coolant, 10% fuel, hydraulic controls and fluids, backup alarm, seat belt, 710 mm (28") grouser shoes, drawbar and counterweight.

Transmission

1 Forward	3.4 km/h	2.1 mph
2 Forward	6.1 km/h	3.8 mph
3 Forward	10.6 km/h	6.6 mph
1 Reverse	4.5 km/h	2.8 mph
2 Reverse	8 km/h	5 mph
3 Reverse	14.2 km/h	8.8 mph
1F – Drawbar Pull	618.5 N	139 lbf
2F – Drawbar Pull	338.2 N	76 lbf
3F – Drawbar Pull	186.9 N	42 lbf

Standards

Brakes	Brakes meet the standard SAE J/ISO 10265 March99
ROPS	Optional ROPS (Rollover Protection Structure) meets the standards SAE J397 OCT95, SAE J1040 MAY94, ISO 3164 1995 and ISO 3471-1

Pipelaying Equipment

Hydraulic Power – 540 L/min at 18 259 kPa/183 bar (143 gpm at 2,650 psi) and 2,100 rpm pump speed independent of torque converter.

Planetary Hydraulic Winches

	Hook		Boom	
Drum diameter	317 mm	12.5 in	317 mm	12.5 in
Flange diameter	610 mm	24 in	610 mm	24 in
Drum length	338 mm	13.3 in	338 mm	13.3 in
Capacity – 19 mm (3/4" diameter)	181 m	595 ft	181 m	595 ft
Wire rope installed – 19 mm (3/4" diameter)	102 m	336 ft	102 m	336 ft
Hook speed (raise) with 6 part line	22 m/min	72.1 ft/min		
Boom – square section standard	7.32 m	24 ft		
Removable counterweight 13 segments, 2 @	300 kg	662 lb		
6 @	535 kg	1,180 lb		
5 @	430 kg	948 lb		
Total weight extendible	9036 kg	19,920 lb		

Lifting Capacity

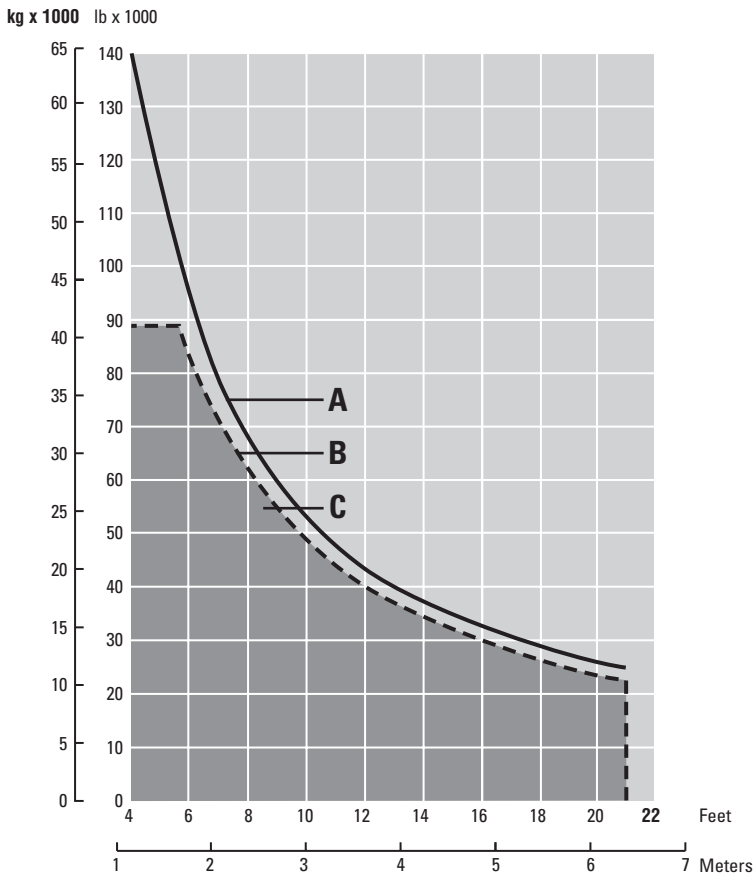

583T LIFT CAPACITY

Specified Equipment:

19 mm (3/4") diameter wire rope
26 672 kg (58,800 lb) minimum breaking strength

6 part load line
5 part boom line

9036 kg (19,920 lb) counterweight extended
boom 7.3 m (24 ft) standard
Total operating weight 45 359 kg (100,000 lb)

A Lift capacity at tipping point*

B Rated load capacity*

C Working range*

* Per ISO 8813:1992

Dimensions

(approximate)

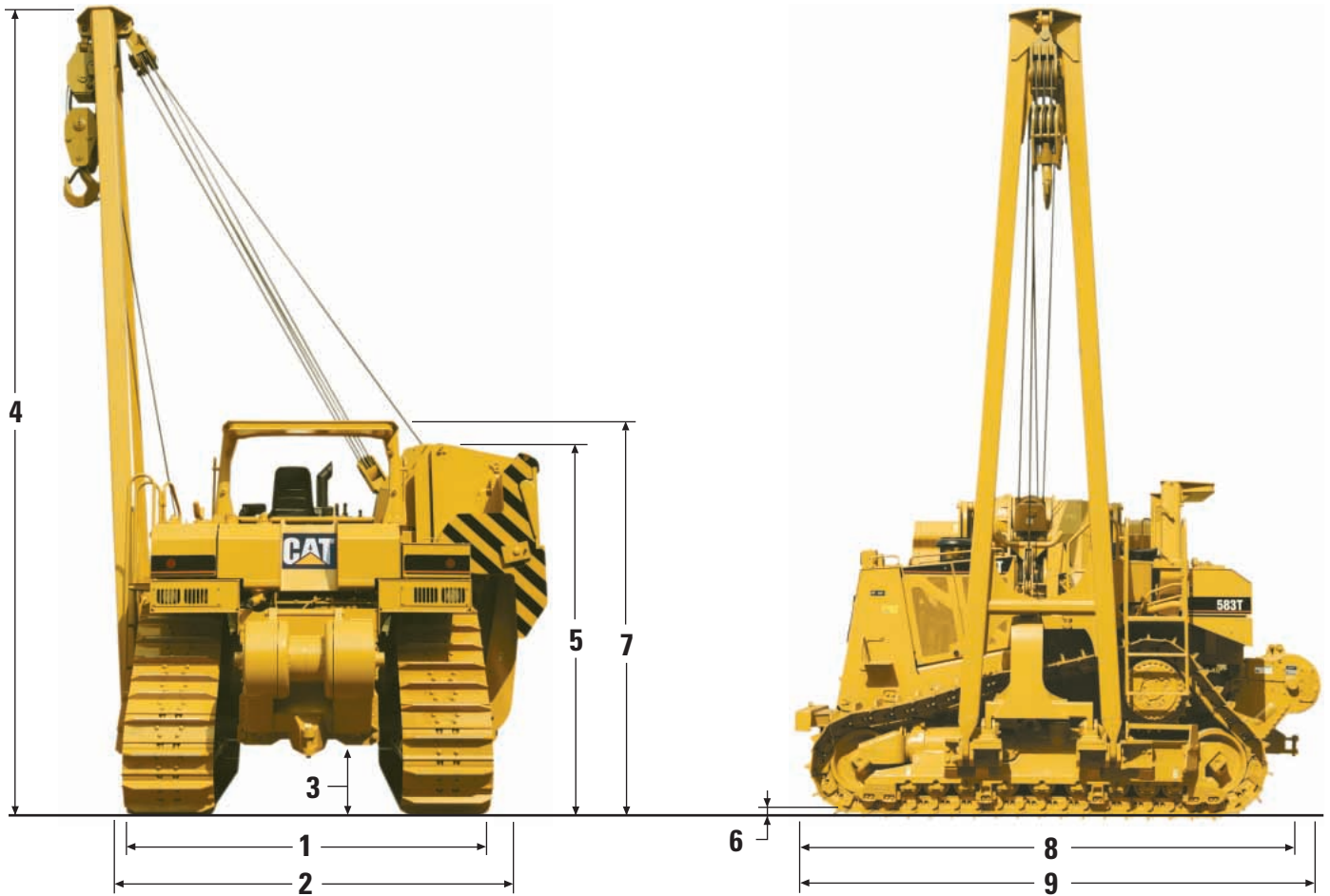

1 Width to outside of track	3048 mm (10'0")
2 Minimum shipping width (counterweight frame, counterweight mounting brackets, boom and boom mounting brackets removed)	3070 mm (10'1")
Shipping width (boom and counterweight removed)	3507 mm (11'6")
3 SAE ground clearance (face of shoe)	483 mm (19.1")
4 Boom height – vertical	8020 mm (26'4")
5 Shipping height without ROPS and boom	3410 mm (11'2")
6 Grouser height	78 mm (3.1")
7 Shipping height to top of optional ROPS (boom removed)	3708 mm (12'2")
8 Operating length (with rear drawbar)	5207 mm (17'1")
9 Operating length (with optional winch)	5385 mm (17'8")

Standard Equipment

Standard equipment may vary. Consult your Caterpillar dealer for details.

ELECTRICAL

- Alarm, Back up
- Alternator, 95-amp
- Batteries, 4, maintenance free
- Converter, 12V, 10 amp with 1 outlet
- Diagnostic connector (starting and charging system)
- Horn, forward warning
- Lights, halogen, 2 front – 2 rear
- Starting receptacle

OPERATOR ENVIRONMENT

- Armrest, adjustable
- Deactivation switch, hydraulic controls
- Pedal, Decelerator
- Pedal, Dual brake
- Horn
- Hour meter
- Monitoring System, electronic warning
- Gauge package:

- Coolant temperature
- Power train oil temperature
- Hydraulic oil temperature

- Governor switch, electronic
- Key start, single
- Seat, vinyl suspension
- Seat belt, retractable
- Service indicator, air cleaner
- Steering system, differential
- Storage compartment

PIPELAYING EQUIPMENT

- Block and Hook, Heavy duty with roller bearings
- Boom, 7.3 m (24 ft)
- Counter weight, extendible segmented 9036 kg (19,920 lb)
- Drawworks, hydraulically actuated and controlled
- Hook with latch

POWER TRAIN

- Advanced Modular Cooling System (AMOCS)
- Aftercooler, air to air (ATAAC)
- Engine, C15 with ACERT™ Technology
- Coolant, extended life with protection to –37° C (–34° F)
- Filter, air with electronic service indicator
- Electric starting, 24 volt direct
- Fan, hydraulically driven (suction)
- Final drives, four planet, double-reduction planetary
- Fuel priming pump, electric
- Muffler
- Parking brake, electronic
- Precleaner with dust ejector
- Prescreener
- Ether starting aid
- Torque divider
- Transmission, electronically-controlled powershift, 3F/3R
- Transmission control module, electronic
- Turbocharger, wastegate
- Water separator

UNDERCARRIAGE

- Carrier roller
- Undercarriage, non-suspended with 9-roller, tubular track roller frame
- Lifetime Lubricated rollers and idlers
- Sprocket, segmented
- Track:
- Adjuster, hydraulic
- Carrier rollers
- Sealed and Lubricated with PPR, medium service, single grouser track shoes, 47 section, 710 mm (28 in)
- Two piece master link

OTHER STANDARD EQUIPMENT

- Bumper, front with towing device
- Drawbar, rigid
- Ecology drains
- Diagnostic pressure taps
- Guards:
- Crankcase
- Power train, hinged
- Radiator, hinged
- Track guiding
- Hydraulics, pilot operated, pipelayer system
- Parts book, CD rom
- Oil cooler, hydraulic
- Product link ready
- S•O•SSM sampling ports
- Steering, electronically controlled power differential
- Vandalism protection for fluid compartments
- Enclosure, Perforated engine door
- Hood, Perforated

Optional Equipment

Optional equipment may vary. Consult your Caterpillar dealer for details.

ELECTRICAL

Alternator, 150 amp

Batteries, heavy duty

OPERATOR ENVIRONMENT

Air conditioning

Cab (includes)

Lights, 8 additional

Sliding windows

Heater

Roof window

Rear pop-out window

3 wipers, (front, rear, door)

Dual pane cab windows

PIPELAYING EQUIPMENT

Boom, 8.5 m (28 ft) and cables

Protection pads, boom and load

POWER TRAIN

Enclosures, arctic engine

Fan, auto reversible

Fast Fuel System

Heater, engine coolant, 120 volt

Heater, diesel fuel

Hood, solid

Starting, low temperature

Oil change system, quick

Prelube, engine, automatic

Coolant, Extended life -50°C (-58°F)

UNDERCARRIAGE

Tracks, pair, Sealed and Lubricated:

762 mm (30 in), PPR Moderate Service

OTHER OPTIONAL EQUIPMENT

Cold weather arrangement

Guards:

Track roller

Radiator core protection grid

Vandalism Protection

Tool kit (dealer installed)

ROPS, roll over protection system

Product link, PL300

Drawbar, heavy duty

Parts Book, paper

Notes

583T Pipelayer

For more complete information on Cat products, dealer services,
and industry solutions, visit us on the web at www.cat.com

© 2006 Caterpillar
All Rights Reserved
Printed in U.S.A.

Materials and specifications are subject to change without notice.
Featured machines in photos may include additional equipment.
See your Caterpillar dealer for available options.

CAT, CATERPILLAR, ACERT, ADEM, their respective logos and
"Caterpillar Yellow," as well as corporate and product identity used herein,
are trademarks of Caterpillar and may not be used without permission.

AEHQ5645-01 (3-06)

Replaces AEHQ5645

CATERPILLAR[®]