

572R Series II Pipelayer



Engine

Engine Model	Cat [®] 3176C	
Gross Power	192 kW	258 hp
Rated Flywheel Power	179 kW	240 hp

Weights

Operating Weight	31 845 kg	70,206 lb
------------------	-----------	-----------

Pipelaying Equipment

Lift Capacity at Tipping Point	40 800 kg	90,000 lb
--------------------------------	-----------	-----------

572R Series II Pipelayer

Excellent response and control for productivity and versatility.

Powertrain

- ✓ The rugged, easy-to-service 3176C engine features the electronically controlled, direct injection fuel system for improved fuel efficiency and reduced emissions. The 3176C meets EPA Tier 2, EU Stage II, and Japan MOC Step 2 exhaust emission regulations. **pg. 4**

Structure

Mainframe is designed and built for durability using the latest technology in engineering and manufacturing. Providing solid support and perfect alignment for major components. **pg. 12**

Advanced Modular Cooling System (AMOCS)

AMOCS utilizes an exclusive two pass cooling system and increased cooling surface area to provide significantly more cooling efficiency than conventional systems. **pg. 5**

Undercarriage

Elevated sprocket design for optimized balance and performance. The final drives are above the work area, isolating them from ground impact for long powertrain component life. **pg. 13**

Drivetrain

Rugged, durable, and reliable components deliver smooth, responsive power and lasting reliability. The Auto-shift and Auto-kickdown features enhance operator comfort. **pg. 6**

Engineered for demanding work.

The 572R Series II power and versatility, combined with rugged components, are designed for tough and varied working conditions.

This machine offers you the reliability and durability you expect from Cat Pipelayers.

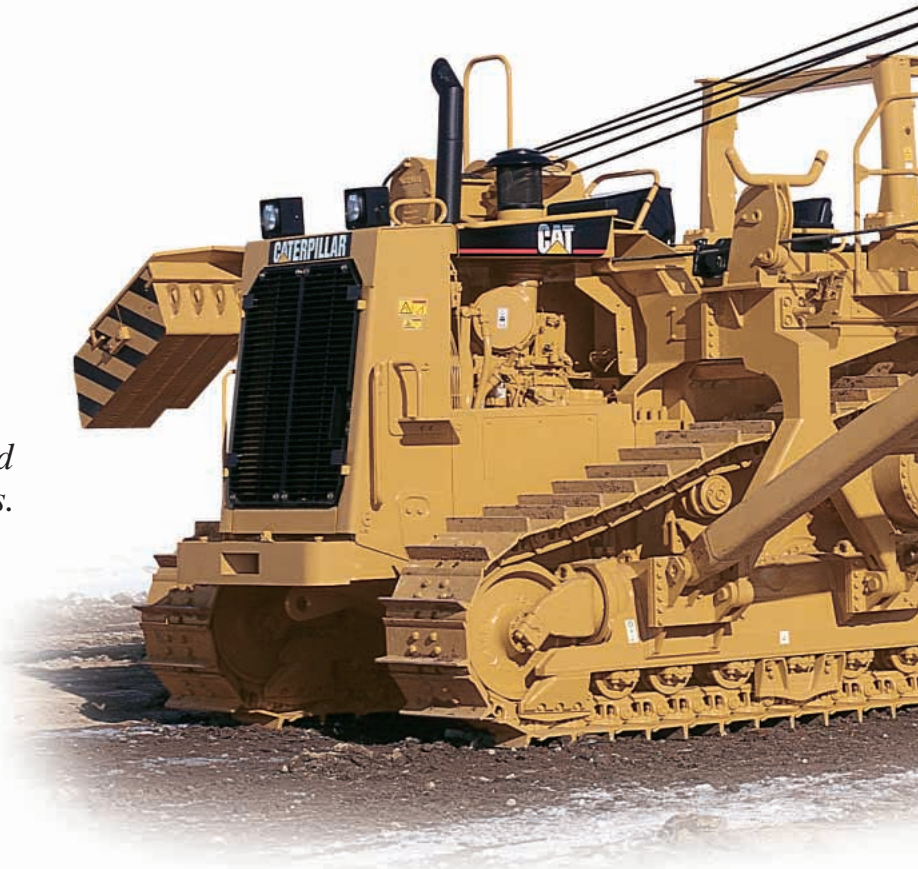

Finger Tip Control

- ✓ Finger Tip Control (FTC) combines steering, machine direction and gear selection into a single control system. These control functions can be simultaneously operated using only one hand for enhanced operator comfort and increased productivity. **pg. 8**

Pipelayer

Hydraulic load line and boom winches provide excellent speed capability. Counterweight and frame design provide excellent stability while offering ample viewing area. **pg. 9**

Operator Station

- ✓ Ergonomically designed for productivity and comfort. Controls are intuitive, low-effort, and easy to reach. Instrument panel is easy to read and informative. Simplified access with ladder on the left rear side of the machine. **pg. 10**

Serviceability

- Major modular components are designed for excellent serviceability and allow fast in-field component exchange. **pg. 14**

Total Customer Support

Your Caterpillar® dealer offers a wide range of services that can be set up with a Customer Support Agreement (CSA). Your dealer can customize a plan for you, covering machine and attachment selection, replacement options, PM service, to total machine maintenance. **pg. 15**



✓ *New Feature*

Powertrain

The 3176C engine, matched with the torque divider and field proven power shift transmission, provides years of dependable service.

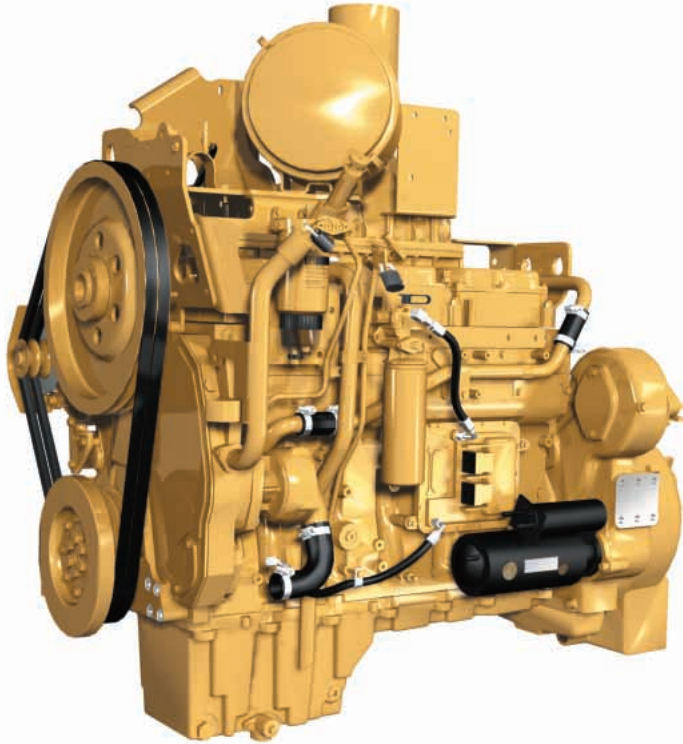

Cat 3176C Engine. The Cat 3176C engine meets EPA Tier 2, EU Stage II, and Japan MOC Step 2 exhaust emission regulations. Major features include:

- Power of 179 kW (240 hp) for superior performance.
- Large displacement electronic engine with lower exhaust emissions and good cold start capability.
- Powertrain to engine link with controlled throttle shifting.

- Higher efficiency turbocharger for improved airflow.
- Fuel/Air Ratio Control to minimize acceleration smoke.

Cylinder Block. Engine durability begins with its foundation — the engine block. The serpentine design of the 3176C block provides maximum strength with reduced weight. A single-piece, deep-skirted design provides a solid base for the durability you require in today's 572R Series II.



Electronic Unit Injector (EUI). The mechanically actuated, electronically controlled unit injector combines an electronic actuator, pump assembly and nozzle into a single, compact unit for reliability and durability. The 3176C fuel system has been tested in thousands of engines in some of the most demanding applications and environments around the world.

Pistons. The two-piece, articulated piston design consists of a forged-steel crown for maximum strength and a cast aluminum skirt to reduce weight. A large piston pin holds the crown, skirt, and connecting rod together. The aluminum skirt runs cooler than conventional pistons, allowing a closer fit to the cylinder liner and providing longer life. The steel crown handles the higher internal pressures of today's engines.

Crankshaft. The crankshaft is steel forging with induction-hardened journals and fillets. The wide center and end main journals and bearings are designed to maintain maximum oil film thickness for excellent lubrication and for cooling the bearings. The result is long life-to-overhaul.

Advanced Modular Cooling System (AMOCS)

AMOCS utilizes an exclusive two pass cooling system and increased cooling surface area to provide significantly more cooling efficiency than conventional systems.

Two-Pass Cooling System. Using a two-pass system, the AMOCS radiator provides a more efficient heat exchange. Coolant is routed from a sectioned bottom tank up the front side, over the top of the core and down the engine side of the core to the bottom tank. This flow pattern allows the coolant to pass through the radiator twice for better cooling.

Modular Design. The cooling elements are individual core modules connected to a sectioned bottom tank. There is no top tank to remove.

Design includes:

- Standard 9 steel fins per 2.54 cm (1 in), or an optional 6 steel fins per 2.54 cm (1 in).
- Brass tube construction within each core for improved reliability.

Separate Circuit Aftercooling.

The 572R Series II features a Separate Circuit Aftercooler. Two of the AMOCS cores are dedicated to the aftercooler coolant circuit to achieve cooler inlet air temperatures, which increases performance and improves engine emissions. A separate water pump is used to circulate the aftercooler coolant.

Serviceability. Modular core design permits removal of a single core without removing the entire radiator, reducing repair costs and downtime. AMOCS eliminates the top tank, side channels and one sealing surface, making it more reliable and easier to service. Also features a site gauge for quick service checks.

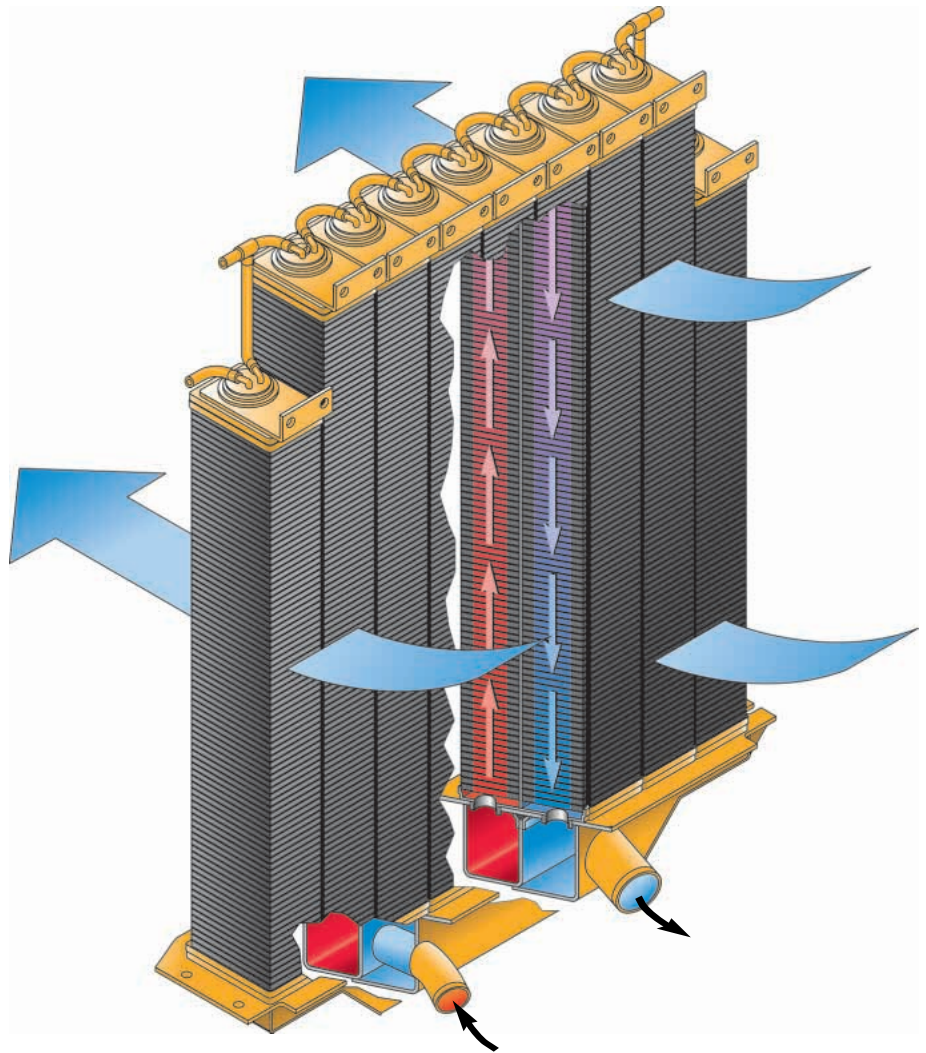

Protection From Leaks. To reduce the potential for coolant leaks, brass tubes are welded to a large, thick header, improving strength of the tube-to-header joint. In conditions where abrasive materials can be airborne, the attachment sand blast grid should be used to inhibit core damage.

Sand Blast Grid. In applications where airborne debris is prevalent, radiator core protection is a concern. To extend radiator life in harsh applications, a sand blast grid is available as an option to deflect the damaging debris the engine fan propels at the radiator.

Drivetrain

Rugged, durable, and reliable components deliver smooth, responsive power and lasting reliability.

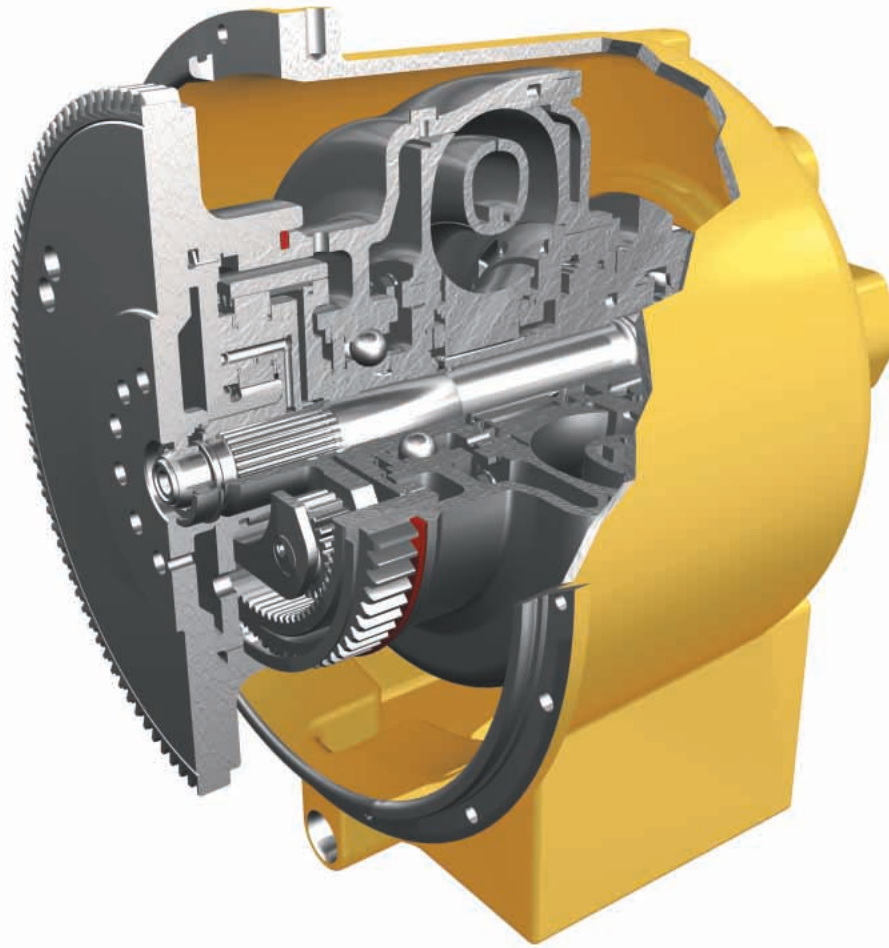

Torque Divider. The 572R Series II single stage torque divider efficiently responds to changing load conditions by providing torque multiplication, therefore increasing drawbar power. Provides protection to the drivetrain components by preventing shock loads. The torque divider is efficiently matched to the powertrain components providing the superior performance you need.

Torque Divider Benefits. The 572R Series II torque divider provides:

- High reliability.
- Proven component design.
- Low dynamic torque.
- Optimum combination of operating efficiency and driveline reliability.
- Components designed to absorb full engine power.

Operating Efficiency and Driveline Reliability. The 572R Series II torque divider attains the best combination of operating efficiency and driveline reliability. Reduces shock loads to the transmission and final drives by acting as a hydrodynamic component between the engine and transmission.

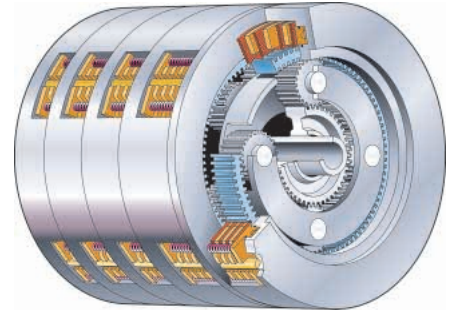

Transmission. The proven planetary power shift transmission features three speeds forward and three speeds reverse and utilizes large diameter, high capacity, oil cooled clutches. To maximize the life of the transmission, the planetary design distributes loads and stresses over multiple gears.

- Controlled throttle shifting regulates engine speed during high-energy directional shifts for smoother operation and longer component life.
- The transmission and bevel gear set are modular by design and easily slide into the machine's rear case.
- Forced oil flow lubricates and cools clutch packs to provide maximum clutch life.
- Load compensating shifting provides smooth engagement of the clutches under loaded conditions.

Load Compensating Shifting. The 572R Series II automatically adjusts the clutch engagement timing according to load factor, resulting in improved performance and operator comfort during speed changes. Load compensating shifting reduces the amount of energy dissipated through the clutches helping extend transmission component life.

Electronic Clutch Pressure Control. The 572R Series II has an additional transmission-shifting feature for added performance and operator comfort — the Electronic Clutch Pressure Control (ECPC). This unique feature provides smoother shifting by regulating and modulating the individual clutches based on current operating conditions.

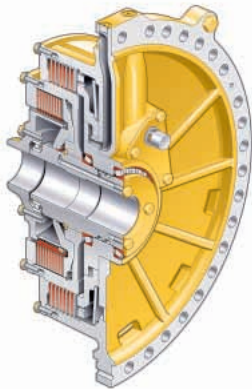

Steering Clutch and Brakes. Oil cooled, hydraulically actuated, large diameter plates and clutch discs provide higher torque capacity and increased service life.

Thick, Large Diameter Plates and Clutch Disks. Thick, large diameter plates and disks provide torque capacity and increased service life.

Brake Housing. Brake housing features cast rib design for durability.

Cooling Oil Valve. Cooling oil valves control oil flow for brake heat dissipation, extending brake life.

Tapered Roller Bearings. Tapered roller bearing design provides excellent service life.

Electronic Steering and Transmission Controls. The 572R Series II provides Finger Tip Control for steering. Soft touch buttons located on the steering controls shift the electronically controlled transmission.



Elevated Final Drive. Final drives are isolated from ground and work tool induced impact loads for extended powertrain life.

Double Reduction Planetary Final Drive. The 572R Series II uses double reduction planetary final drives. The final drives are designed with three (3) planetary gears to spread high torque loads out evenly for long final drive life.

Splash Lubrication & Symmetric Duo-Cone® Seals. Splash lubrication and Duo-Cone seals maximize service life.

Finger Tip Control

Finger Tip Control (FTC) combines steering, machine direction and gear selection into a single control system, which can be operated with one hand for enhanced operator comfort and increased productivity.



Three-Speed Forward/Reverse Gear Selection. Three-speed forward/reverse gear selection is achieved simply by pressing the yellow speed selection buttons. These buttons are integrated into the Finger Tip Control group.

- Automatic shifting features and reduced lever efforts for easier upshift and downshift, increased operator comfort, reduced fatigue, and precise control.

Electronic Clutch and Brake Steering System. The electronic clutch and brake steering system incorporates low effort finger tip levers allowing the operator to work more precisely in close areas, around structures, obstacles and grade stakes. Pulling the left or right finger paddle causes the machine to turn according to the amount of paddle displacement.

- Aimed at operator comfort is the electric vertical adjustment of the FTC control group. This positions the operator's arm for efficient ergonomics.

Machine Direction. Moving the machine's transmission forward/neutral/reverse direction lever controls machine direction.

Auto-shift and Auto-kickdown.

Auto-shift and Auto-kickdown include the following features:

- Auto-shift allows the operator to preselect a forward and reverse gear for frequent directional changes. The settings include first forward to second reverse, second forward to second reverse and second forward to first reverse.
- Auto-kickdown automatically downshifts from any gear when the machine detects a significant increase in load.

Pipelayer

Caterpillar pipelayer system includes winch and boom, counterweight and frame.



Winches and Boom.

- Independent hydraulic winches drive boom and hook drawworks.
- Oil-disc brakes provide smooth operation, positive retention of boom and hook positions.
- Modular design allows fast replacement, easy field service, and testing.
- Infinitely variable speed controls for boom and hook allow precise control.
- Emergency free-fall function on load line control allows the operator to drop the load quickly.
- Tubular, cast-steel boom is rugged, delivers better fatigue life.
- Replaceable boom-mount bearings.



Counterweight and Frame.

- The narrow profile of the counterweight design minimizes impact on viewing area.
- Mainframe consists of box-section frame welded to a cast bevel gear case.
- Counterweight is extended hydraulically for load balance.
- Service latch mechanically locks counterweight in extended position.



Drawbar.

- Large jaw opening and pin diameter.
- Able to tow wide range of attachments.

Operator Station

Ergonomically designed for operator's comfort and productivity.



Seat. Ergonomically designed and fully adjustable for maximum comfort. The seat cushion reduces the pressure on the lower back and thighs while allowing unrestricted arm and leg movement.



Dash. The instrument panel, with easy to read analog gauges and warning lamps, keeps the operator aware of any potential problems. All gauges and readouts are easily visible in direct sunlight. Auto-shift and Auto-kickdown controls are located within easy reach of the operator. New footpads keep the operator stable and comfortable during side slope applications.

Caterpillar Monitoring System.

Provides gauges to monitor the temperature of the engine coolant, hydraulic oil, and power train oil, plus the fuel level. Also provides alert indicators that monitor engine oil pressure, inlet manifold temperature, coolant flow, electrical charging system, transmission oil filter, air filter service indicator, engine fault warning light, work tool warning indicator, and hydraulic filter.

The monitoring system has:

- Easy to read digital tachometer.
- Self-test at every start.
- Fault code for easy troubleshooting.



Counterweight Control. Adjusts the position of the counterweight for added machine stability.

Finger Tip Control. Finger Tip Control (FTC) combines steering, machine direction and gear selection into a single control system, which can be operated with one hand for enhanced operator comfort and precise control.



Ergonomic Work Tool Controls.

Pipelayer controls are low effort and allow simultaneous, precise positioning of the load line and boom with one hand.

Load Line Speed Range. Allows the operator to select high or low.

Power Supply. The voltage converter provides two 12-volt power supplies.

Access Ladder. Direct access to the operator's station utilizing ladder on left side of the machine.

Structure

Engineered and manufactured to provide durability in the most demanding work.

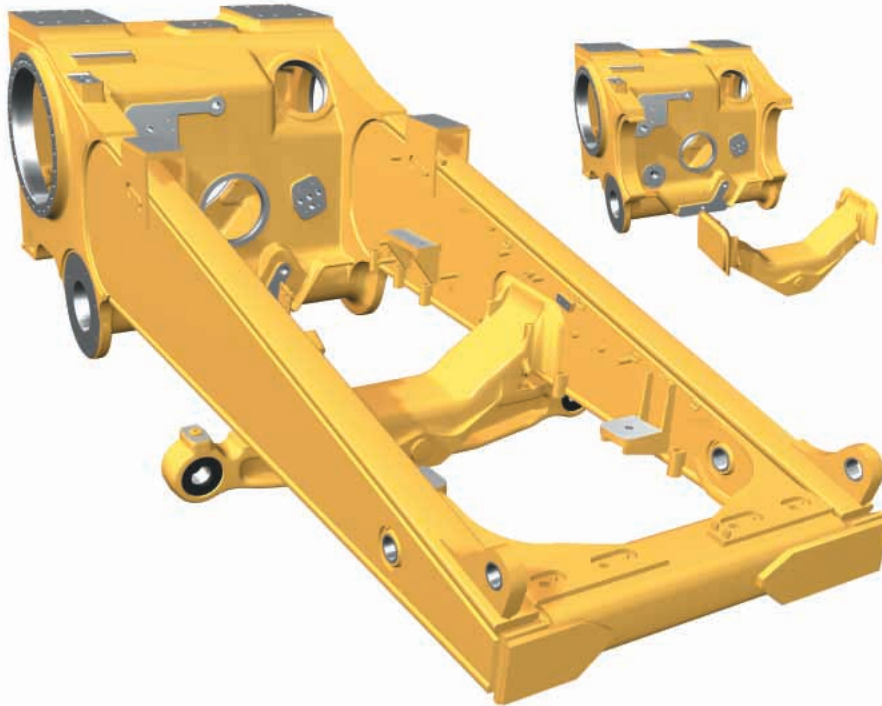

Frame and Castings. Case and frames are built to absorb high impact shock loads and torsional forces. Castings are strategically located within the frame to add additional strength. Caterpillar uses robotic welding techniques in the assembly of the case and frames. This insures quality and reliability throughout the structure. The one-piece all welded chassis provides superior strength over bolted designs, and provides stiffness and durability.

- High strength steel mainframe resists impact shock loads.
- Computer-aided finite element analysis is used to evaluate and ensure high durability of the chassis by computer modeling it and identifying high stress area.
- Full scale structural testing to test integrity of the structures.

- Robotic welding provides deep penetration and consistency for long life, and reduces the chance for errors that may be made during manual welding.
- Precision top level machining for perfect alignment of bores and surfaces minimizes out of tolerance wear patterns and improves durability.
- Non-oscillating roller frames for greater stability in pipelaying applications.
- The recoil system is sealed and lubricated.
- Improved pipelayer structure mounting.



Optional Roll Over Protective Structure. Provides for increased operator protection.

Undercarriage

The Caterpillar elevated sprocket undercarriage arrangement is designed for better balance, performance, and component life.

Elevated Final Drive.

- Isolates final drives from ground and work tool induced impact loads for extended powertrain life.
- Keeps sprocket teeth, bushings, and final drive away from abrasive materials and moisture.
- Single reduction planetary final drives provide long-lasting performance and durability.

Steel Sprocket Segments. 572R Series II sprocket segment material is metallurgically optimized to be fracture resistant. This allows the sprocket to live longer and better match a bushing turn.



Undercarriage Arrangements.

Standard Arrangement: 660 mm (26 in) single grouser shoes made from heat-treated, rolled steel for added strength. Long track frame and wide gauge enhance track contact area, providing a very stable working base.

Low Ground Pressure (LGP) arrangement (optional):

- 760 mm (30 in) single grouser slipped shoes.
- Specially designed to work in soft and spongy conditions.
- Wide track shoes increase track contact area and reduce ground pressure for excellent flotation.

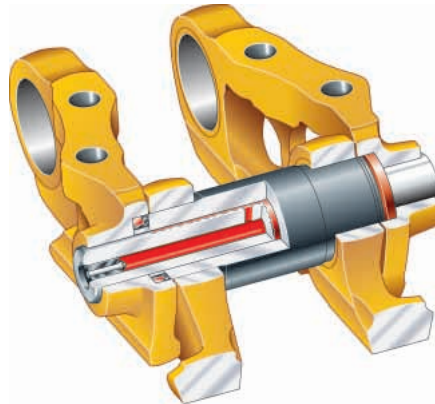

Heavy-Duty Sealed and Lubricated Track. Permanently coats the track pin with a sealed-in lubricant, minimizing metal-to-metal contact.

- Virtually eliminates internal pin and bushing wear.
- Lubricant is held in a reservoir in the track pin.

Complete Guarding. Caterpillar undercarriages are designed with full length guarding on top of the track roller frame. This prevents abrasive materials from falling down on moving parts.



Roller Frames. Roller frames are tubular, to resist bending and twisting.

Recoil System. The recoil system is protected from the elements and maintained in a sealed oil-filled cavity for years of reliable service.

Hydraulic Track Adjuster. Adjusting the track on the 572R Series II is done hydraulically by removing a plate on the top of the roller frames. Adding or removing grease adjusts the track for optimum operation.

Guiding Guards. Heavy-duty track guiding/guard attachment provides maximum protection to track pin bosses roller flanges, and end guides.

Optional High Flange Improved Track Rollers. Combined with center or full length roller guard attachments greatly improve track guiding for demanding side slope conditions.

Serviceability

Modular design moves Caterpillar a generation ahead in simplifying service and maintenance.



Product Link. This option allows the customer or dealer to obtain machine diagnostics and location from their offices. Product Link provides updates on service meter hours, machine condition, machine location, as well as integrated mapping/route planning.



Electronic Monitoring System.

Features a flexible monitoring system that is easily upgraded by flashing software rather than replacing the module, reducing parts cost. As technology changes and new electronics and software become available, the machine's monitoring system is easily updated.



Built-in Serviceability. Less service time means more working time. Major components are designed as modules and most can be removed without disturbing or removing other components.

Diagnostics. Cat 572R Series II diagnostic and troubleshooting capabilities are among the best. The machine dashboard allows for quick identification of a problem and its cause, utilizing a three level warning system. Diagnostic connector allows Caterpillar dealers to quickly troubleshoot or access stored data with the use of Electronic Technician (Cat ET) or ECAP.

Ecology Drains. Ecology drains provide an environmental method to drain fluids. Standard for the engine oil, coolant, hydraulic oil, fuel tank, and power train case. Optional for the transmission and torque converter.

Advanced Modular Cooling System.

Individual radiator core modules are easily serviced without major component removal.

Easy Engine Maintenance. Many parts can be rebuilt and are available as remanufactured components.

- Parent-metal block can be rebored twice and dry-sleeved.
- Connecting rods can be removed through cylinder tops.
- Camshaft followers and push rods can be replaced without removing camshaft.
- Extended oil and engine filter change intervals up to 500 hours.

S-O-SSM Analysis. Scheduled Oil Sampling made easier through live sampling ports for the engine oil, power train, coolant, and hydraulics.

Total Customer Support

Excellent parts availability and the best service capability help increase productivity.

Product Support. Your Cat Dealer offers a wide range of services that can be set up under a Customer Support Agreement when you purchase your equipment. Your dealer will help you choose a plan that can cover everything from the machine and attachment selection to replacement. This will help you get the best return on your investment.

Remanufactured Components. Save money with remanufactured parts. You receive the same warranty and reliability as new products at a cost savings of 40 to 70 percent.

Service Capability. Whether in the dealer's fully equipped shop or in the field, you will get trained service technicians using the latest technology and tools.

Selection. Make detailed comparisons of the machines you are considering before you buy. How long do components last? What is the cost of preventive maintenance? What is the true cost of lost production? Your Cat Dealer can give you precise answers to these questions.

Purchase. Consider the financing options available as well as day-to-day operating costs. This is also the time to look at dealer services that can be included in the cost of the machine to yield lower equipment owning and operating costs over the long run.



Replacement. Repair, rebuild, or replace? Your Cat Dealer can help evaluate the cost involved so you can make the right choice.

Maintenance. More and more equipment buyers are planning for effective maintenance before buying equipment. Choose from your dealer's wide range of maintenance services at the time of your purchase. Repair option programs guarantee the cost of repairs up front. Diagnostic programs such as Scheduled Oil Sampling and Technical Analysis help avoid unscheduled repairs.

Engine

Engine Model	Cat 3176C	
Gross Power	192 kW	258 hp
Rated Flywheel Power	179 kW	240 hp
Net Power — ISO 9249	179 kW	240 hp
Net Power — EEC 80/1269	179 kW	240 hp
Net Power — SAE J1349	177 kW	238 hp
Net Power — DIN 70020	248 PS	
Bore	125 mm	4.9 in
Stroke	140 mm	5.5 in
Displacement	10.3 L	629 in ³

- Engine Ratings at 2100 RPM
- Meets U.S. EPA Tier 2, European Union Stage II, and Japan MOC Step 2 exhaust emission regulations.
- Net power advertised is the power available at the flywheel when the engine is equipped with fan, air cleaner, muffler, and alternator.
- No derating required up to 2286 m (7,500 ft) altitude, beyond 2286 m (7,500 ft) automatic derating occurs.

Transmission

1 Forward	3.52 kph	2.19 mph
2 Forward	6.1 kph	3.79 mph
3 Forward	10.54 kph	6.55 mph
1 Reverse	4.54 kph	2.82 mph
2 Reverse	7.85 kph	4.88 mph
3 Reverse	13.58 kph	8.44 mph

Undercarriage

Number of Shoes — Each Side	43	
Track Rollers — Each Side	7	
Track Gauge	2235 mm	88 in
Track on Ground	3176 mm	125 in
Track Shoe Width — Standard	660 mm	26 in
Track Shoe Width — Optional	760 mm	30 in
Ground Contact Area — Standard Shoe	4.19 m ²	6,500 in ²
Ground Contact Area — Optional Shoe	4.81 m ²	7,462 in ²
Ground Pressure — Standard Shoe	74.46 kPa	10.8 psi
Ground Pressure — Optional Shoe	64.88 kPa	9.41 psi

Weights

Operating Weight	31 845 kg	70,206 lb
Shipping Weight	30 850 kg	68,013 lb

- Operating Weight: Includes lubricants, coolant, 100% fuel, hydraulic controls and fluids, backup alarm, seat belt, 660 mm (26 in) single grouser shoes, drawbar, counterweight, boom and pulley blocks, and operator.
- Shipping Weight: Includes lubricants, coolant, 10% fuel, hydraulic controls and fluids, backup alarm, seat belt, 660 mm (26 in) single grouser shoes, drawbar, and counterweight.

Pipelaying Equipment

Lift Capacity at Tipping Point	40 800 kg	90,000 lb
Boom Length	6.1 m	20 ft
Hook Winch Drum Diameter	254 mm	10 in
Rope Minimum Breaking Strength	261.66 kN	58,800 lb
Boom Winch Drum Diameter	224 mm	8.5 in
Hook Winch Flange Diameter	457 mm	18 in
Boom Winch Flange Diameter	406 mm	16 in
Hook Winch Drum Length	279 mm	11 in
Boom Winch Drum Length	254 mm	10 in
Diameter — Wire Rope	19 mm	0.75 in
Hook Winch Capacity — 19 mm (3/4 in) Diameter	80.16 m	263 ft
Boom Winch Capacity — 19 mm (3/4 in) Diameter	51.82 m	170 ft
Hook w/ Wire Rope Installed — 19 mm (3/4 in) Diameter	50.29 m	165 ft
Boom w/ Wire Rope Installed — 19 mm (3/4 in) Diameter	40.23 m	132 ft
Boom Line Speed	73 m/min	241 ft/min
4 Part Line Hook Speed (Lo)	11 m/min	36 ft/min
4 Part Line Hook Speed (Hi)	22 m/min	75 ft/min
Removable Counterweight — Number of Segments	9	
Removable Counterweight — 2 Each At	370 kg	815 lb
Removable Counterweight — 7 Each At	478.5 kg	1,055 lb
Removable Counterweight — 9 Segments, Total Of	4089 kg	9,015 lb
Total Weight Extendable	5073 kg	11,184 lb

- Hydraulic power (55.7 gpm at 2700 psi and 2200 rpm pump speed independent of torque converter) (211 L/min at 18 616 kPa/186 bar)

Hydraulic Controls

Type	Pressure compensating piston-type pump.	
Output — Maximum	281 L/min	74.2 gal/min
Relief Valve Setting — Counterweight	17 240 kPa	2,500 psi
Relief Valve Setting — Hook and Boom Winch	33 000 kPa	4,786 psi

- Pump output at 2231 rpm (2100 engine rpm) and maximum pressure at 7000 kPa (1,015 psi).

Service Capacities

Fuel Tank	479 L	126.5 gal
Crankcase (with Filter)	31 L	8.2 gal
Transmission, Bevel Gear, and Steering Clutch	183 L	48.3 gal
Final Drives (each)	13 L	3.4 gal
Cooling System	77.4 L	20.4 gal
Hydraulic Tank	54.1 L	14.3 gal
Recoil Spring Compartments (each)	57 L	15 gal

Standards

- Brakes meet the standard SAE J/ISO 10265 MARCH99.
- Optional ROPS (Rollover Protection Structure) offered by Caterpillar for the machine meets the criteria of SAE J397 OCT95, SAE J1040 MAY94, ISO 3164 1995, and ISO 3471-1:1994.

Lifting Capacity

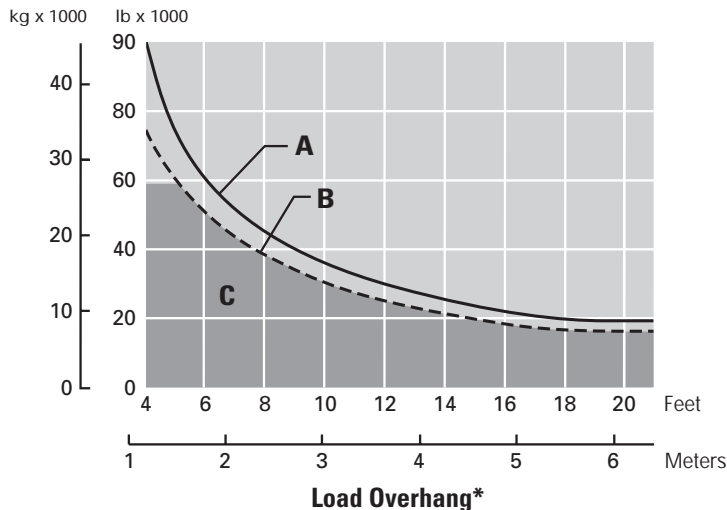

Specified Equipment

- Diameter wire rope 19 mm 0.75 in
- Rope minimum breaking strength 261.66 kN 58,800 lb
- 4 part load line
- 4 part boom line
- Counterweight extended 5073 kg 11,184 lb
- Standard boom 6.10 m 20 ft
- Total operating weight 31 845 kg 70,206 lb

A Lift capacity at tipping point*

B Rated load capacity*

C Working range*

* Per ISO 8813:1992

Dimensions

All dimensions are approximate.

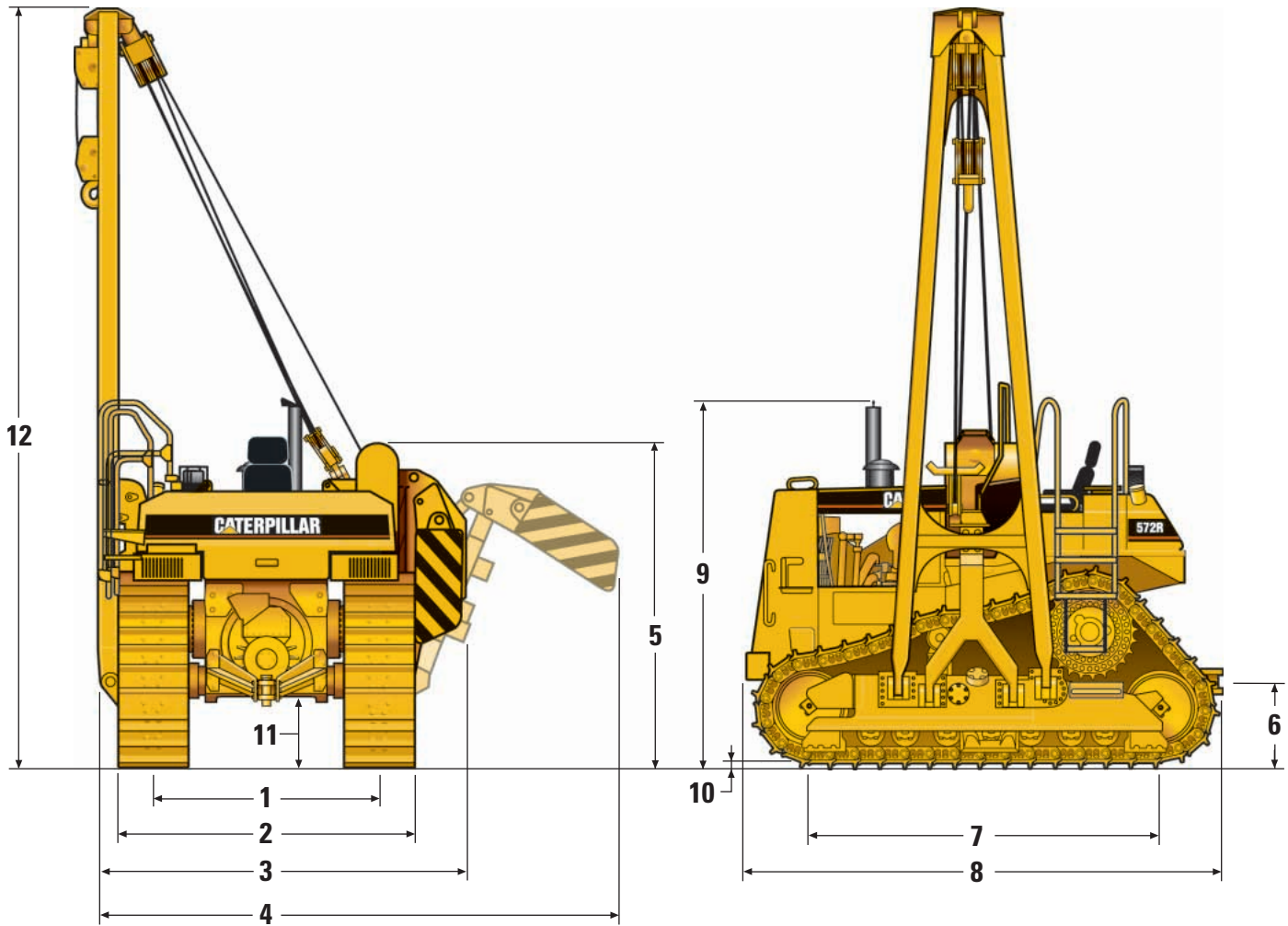

1	Track Gauge	2235 mm	88 in
2	Width of Tractor — Standard Shoes	2895 mm	114 in
3	Width of Tractor — Boom Removed	3659 mm	144 in
4	Width of Tractor — Counterweight Extended	5228 mm	206 in
5	Machine Height — Tip of Grouser to Top of Winch	2895 mm	114 in
6	Drawbar Height (Center of Clevis)	634 mm	24.9 in

7	Length of Track on Ground	3176 mm	125 in
8	Operating Length (with Drawbar)	4736 mm	186 in
9	Height to Top of Stack	3553 mm	133 in
10	Grouser Height	71 mm	2.8 in
11	Ground Clearance (SAE J1234)	416 mm	16.4 in
12	Boom Height — Tip of Grouser at SAE 4 ft (1.22 m) Overhang	6728 mm	265 in

Standard Equipment

Standard equipment may vary. Consult your Caterpillar dealer for details.

ELECTRICAL

- Alarm, back-up
- Alternator, 70-amp
- Converter, 10-amp/12-volt
- Diagnostic connector (starting and charging)
- Horn, forward warning
- Hour meter
- Lights, 2 forward, 2 rear
- Starting receptacle, 24-volt direct

OPERATOR ENVIRONMENT

- Armrests, adjustable
- Brake pedal
- Decelerator pedal and switch
- Engine air cleaner service indicator
- Engine RPM display/gear display
- Foot pegs for slope work
- FTC control for Clutch and Brake steering
- Monitoring System, Electronic (EMS III)
 - coolant temperature, power train oil, hydraulic and fuel gauge, tachometer, odometer, gear indicator
 - diagnostic functions
- Power points, two 12-volt
- Pre-start coolant level monitoring system
- Product Link ready
- Seat, vinyl suspension
- Seat belt, retractable 76 mm (3 in)
- Storage and literature compartment
- Transmission shift points selection
- Travel speed and gear limiter, electronic

PIPELAYER

- Block and hook
- Boom, 6.10 m (20 ft)
- Counterweight, extendible segmented 4089 kg (9,015 lb)
- Hydraulics, pipelayer system

UNDERCARRIAGE

- Adjuster, hydraulic track
- Carrier rollers
- Heavy-duty sealed and lubricated tracks
- Lifetime lubricated idlers and track rollers
- Master link, two-piece
- Sprockets, segmented
- Track frame, 7 rollers
- Track with single grouser track shoes
 - 43-section, 660 mm (26 in)

POWERTRAIN

- 3176C EUI Caterpillar diesel engine with:
 - Advanced Modular Cooling System (AMOCS)
 - Brake system, service, parking and emergency
 - Coolant, extended life
 - Drains, ecology (engine oil, coolant, hydraulic oil, fuel tank, power train case)
 - Fan, blower
 - Final drives, 3-planet double reduction planetary
 - Fuel priming pump
 - Fuel/Water separator
 - Muffler
 - Precleaner with strata tube dust ejector
 - Prescreener
 - Starting aide, ether
 - Shifting, auto-shift (2F/2R, 2F/1R, 1F/2R)
 - Shifting, auto-kickdown (auto downshift)
 - Shifting, controlled throttle
 - Steering system, FTC Clutch and Brake
 - Torque divider
 - Transmission, power shift,
 - three-speed planetary with torque converter

OTHER STANDARD EQUIPMENT

- Altitude operation capability,
 - 2286 meter (7,500 ft) without derating
- Bumper, Front with towing device
- Diagnostic pressure taps, centralized ecology drains
- Extended service intervals (500 hours)
- Guards:
 - Center track-guiding
 - Crankcase, normal service
 - End track-guide
 - Hinged bottom
 - Instrument panel
 - Radiator, hinged
 - Rear
- Hood, perforated
- Implement oil filter
- Keyed lockable enclosures
- Load sensing hydraulics
- Radiator doors, louvered, hinged
- Rigid drawbar
- S•O•S analysis taps for engine, transmission,
 - and implement fluids
- Transmission remote pressure taps
- Vandalism protection

Optional Equipment

Optional equipment may vary. Consult your Caterpillar dealer for details.

	kg	lb		kg	lb
Electrical:			Power Train:		
Alternator, 70-amp brushless	13	29	Cooling, high ambient	3	7
Alternator, 100-amp brushless	14	31	Drains, ecology (transmission, torque converter)	4	9
Converter, 20-amp, 12-volt	1	2	Fan, reversible	0	0
Guards:			Fast fuel system	3	7
Crankcase, extreme service	80	176	Grid, radiator core sand blast	17	38
Radiator, heavy-duty, hinged grill	48	106	Oil change system	9	20
Rear, heavy-duty	71	157	Undercarriage:		
Track guiding			Track groups		
Moderate service	85	187	760 mm (30 in) MS HD, clipped	457	1005
Heavy-duty	107	236	Starting Aids:		
Track roller, full	405	893	Batteries, heavy-duty	15	33
Operator Environment:			Heater, engine coolant	3	7
Armrest, adjustable electric	55	121			
Pedals, dual brake	0	0			
ROPS, rollover protection system	477	985			
Pipelayer:					
Boom, 7.3 m (24 ft)	1183	2,608			
Boom, omission 6.1 m (20 ft)	906	1,997			
Hook, latched	3	7			

Notes

Notes

Notes

572R Series II Pipelayer

AEHQ5574 (3-04)

Replaces AEHQ5316 (9-98)

For more complete information on Cat products, dealer services,
and industry solutions, visit us on the web at www.CAT.com

© 2004 Caterpillar
Printed in U.S.A.

Materials and specifications are subject to change without notice.
Featured machines in photos may include additional equipment.
See your Caterpillar dealer for available options.

CATERPILLAR[®]